

**SUBMIT BID TO:
Via Bonfire Web Portal
UNIVERSITY OF CENTRAL FLORIDA**

Phone: (407) 823-2661

www.procurement.ucf.edu

<https://ucfprocurement.bonfirehub.com/opportunities/69636>

Your submission must be uploaded, submitted, and finalized prior to the closing time on **July 15, 2022 at 3:00pm EST**. We strongly recommend that you give yourself sufficient time and at least ONE (1) day before the closing time to begin the uploading process and to finalize your submission. See **Attachment 4** for submittal instructions.

University of Central Florida

INVITATION TO BID

Commodities

Acknowledgment Form

Page 1 of 47 Pages

BIDS WILL BE OPENED **July 15, 2022 at 3:00pm EST**

ITB NO. **2021-23TC**

and may not be withdrawn within **120** days after such date and time.

ADVERTISEMENT DATE:

June 16, 2022

ITB TITLE: **Installation of Experimental Beds for Filtration Media and Decommission**

FEDERAL EMPLOYER IDENTIFICATION NUMBER

SUPPLIER NAME

REASON FOR NO BID:

SUPPLIER MAILING ADDRESS

CITY - STATE - ZIP CODE

POSTING OF BID TABULATIONS

AREA CODE

TELEPHONE NUMBER

Bid tabulations with intended award(s) will be posted for review by interested parties on the Procurement Services solicitation webpage and will remain posted for a period of 72 hours. Failure to file a protest in accordance with BOG regulation 18.002 or failure to post the bond or other security as required in BOG regulation 18.003 shall constitute a waiver of protest proceedings.

FAX:

EMAIL:

Government Classifications

Check all that apply

- | | |
|--|---|
| <input type="checkbox"/> African American | <input type="checkbox"/> American Woman |
| <input type="checkbox"/> Asian-Hawaiian | <input type="checkbox"/> Government Agency |
| <input type="checkbox"/> Hispanic | <input type="checkbox"/> MBE Federal |
| <input type="checkbox"/> Native American | <input type="checkbox"/> Non-Minority |
| <input type="checkbox"/> Non-Profit Organization | <input type="checkbox"/> PRIDE |
| <input type="checkbox"/> Small Business Federal | <input type="checkbox"/> Small Business State |

I certify that this bid is made without prior understanding, agreement, or connection with any corporation, firm or person submitting a bid for the same materials, supplies, or equipment and is in all respects fair and without collusion or fraud. I agree to abide by all conditions of this bid and certify that I am authorized to sign this bid for the bidder and that the bidder is in compliance with all requirements of the Invitation to Bid, including but not limited to, certification requirements. In submitting a bid to an agency for the State of Florida, the bidder offers and agrees that if the bid is accepted, the bidder will convey, sell, assign or transfer to the State of Florida all rights, title and interest in and to all causes of action it may now or hereafter acquire under the anti-trust laws of the United States and the State of Florida for price fixing relating to the particular commodities or services purchased or acquired by the state of Florida. At the state's discretion, such assignment shall be made and become effective at the time the procurement agency tenders final payment to the bidder.

GENERAL CONDITIONS

SEALED BIDS: All bid sheets and this form must be executed and submitted as specified in Section 2. Bid prices not submitted on attached bid price sheets when required may be rejected. All bids are subject to the terms and conditions specified herein. Those which do not comply with these terms and conditions are subject to rejection. The terms Contractor, Vendor, and Supplier are used interchangeably in this document.

1. EXECUTION OF BIDS: Each bid must contain a manual signature of the representative authorized to legally bind the Supplier to the provisions herein. All spaces requesting information from the Supplier are to be completed. Each bid must be typed or printed in ink. Use of erasable ink is not permitted. All corrections to prices made by the bidder are to be initialed.

2. NO BID SUBMITTED: If not submitting a bid, respond by returning only this bidder acknowledgment form, marking it "NO BID," and explaining the reason in the space provided above. Failure to respond without justification may be cause for removal of the bidder's name from the bid mailing list. NOTE: To qualify as a respondent, the bidder must submit a "NO BID," and it must be received no later than the stated bid opening date and hour.

AUTHORIZED SIGNATURE

AUTHORIZED NAME (TYPED/PRINTED)

TITLE

CONTACT NUMBER

3. BID OPENING: The bid opening shall be public, on the date, time, and location specified on the bid form. It is the bidder's responsibility to assure that the bid is delivered at the proper time and place of the bid opening. Bids which for any reason are not so delivered will not be considered. Offers by telegram or telephone are not acceptable. A bid may not be altered after the opening of the bids unless allowed by the Assistant Vice President of Tax, Payables & Procurement or designee in accordance with established procedures.

NOTE: Bid tabulations will be posted on the Procurement Services solicitation webpage.

4. PRICES, TERMS AND PAYMENT: Firm prices should be bid and include all services/commodities rendered to the purchaser.

(a) TAXES: The State of Florida is a tax-immune sovereign and exempt from the payment of all sales, use and excise taxes.

(b) DISCOUNTS: Cash discount for prompt payment shall not be considered in determining the lowest net cost for bid evaluation purposes.

(c) MISTAKES: Bidders are expected to examine the conditions, scope of work, bid prices, extensions, and all instructions pertaining to the services involved. Failure to do so will be at the bidder's risk. In case of a mistake in extensions, the unit price will govern.

(d) INVOICING AND PAYMENT: All Suppliers must have on file a properly executed W-9 form with their Federal Employer Identification Number prior to payment processing.

Suppliers shall submit properly certified original invoices to:

Division of Finance
12424 Research Parkway, Suite 300
Orlando, Florida 32826-3249

Invoices for payment shall be submitted in sufficient detail for a proper pre-audit and post-audit. Prices on the invoices shall be in accordance with the price stipulated in the contract at the time the order is placed. Invoices shall reference the applicable contract and/or purchase order numbers. Invoices for any travel expenses shall be submitted in accordance with the State of Florida travel rates at or below those specified in Section 112.061, Florida Statutes and applicable UCF policies. Travel reimbursement must be made using the UCF Voucher for Reimbursement of Traveling Expenses available on the web at <https://fa.ucf.edu/travel-payables-forms/>.

Final payment shall not be made until after the contract is complete unless the University has agreed otherwise.

Interest Penalties: Supplier interest penalty payment requests will be reviewed by the UCF vendor ombudsman, whose decision will be final.

Vendor Ombudsman: A vendor ombudsman position has been established within the UCF Division of Finance. It is the duty of this individual to act as an advocate for Suppliers who may be experiencing problems in obtaining timely payments(s) from the University of Central Florida. The vendor ombudsman can be contacted at (407) 882-1082 or by mail at the address in paragraph 4(d) above.

The ombudsman shall review the circumstances surrounding non-payment to determine if an interest payment is due and the amount of the payment and shall ensure timely processing and submission of the payment request in accordance with University policy.

5. CONFLICT OF INTEREST: Submission of this Invitation to Bid (ITB) shall certify that the Bidder is aware of the requirements of Chapter 112, Florida Statutes and in compliance with the requirements of Chapter 112, Florida Statutes and other laws and regulations concerning conflicts of interest in dealing with entities of the State of Florida. The Bidder certifies that its directors and/or principal officers are not employed and/or affiliated with the University unless a current Conflict of Interest (Report of Outside Activity/Employment) form has been completed, executed by such director or officer, and approved in accordance with applicable University policies or rules. Violation of this section by the Bidder shall be grounds for rejection of the bid or cancellation of any contract or purchase order resulting from this ITB, without penalty to the University of Central Florida. No person or firm who receives a contract to perform a feasibility study for potential implementation of a subsequent contract, participates in the drafting of a competitive solicitation, assists in design, or develops a program for future implementation shall be eligible to contract with the University of Central Florida for any project dealing with that specific subject matter. Bidders must disclose with their bids any such conflict of interest dealing with that specific subject matter in accordance with Chapter 255, Florida Statutes.

6. AWARDS: At the sole discretion of the University of Central Florida, the right is reserved to reject any and all bids or waive any minor irregularity or technicality in bids received. Bidders are cautioned to make no assumptions unless their bid has been evaluated as being responsive. Product substitutions may be submitted for evaluation of equivalency unless specifically indicated otherwise. Bidders shall have the burden of proof of equivalency.

7. GOVERNMENTAL RESTRICTIONS: In the event any governmental restrictions may be imposed which would necessitate alteration of the material quality of the services offered on this bid or performance of the items offered on this bid prior to their completion, it shall be the responsibility of the successful bidder to notify the purchaser at once, indicating in writing the specific regulation which requires an alteration. The University of Central Florida reserves the right to accept any such alteration, including any price adjustments occasioned thereby, or to cancel the contract at no expense to the University.

8. LEGAL REQUIREMENTS: Applicable provisions of all federal, state, county and local laws, and of all ordinances, rules and regulations shall govern the development, submittal and evaluation of all bids received in response hereto and shall govern any and all claims and disputes which may arise between person(s) submitting a bid response hereto and the University of Central Florida, by and through its officers, employees and authorized representatives, or any other person, natural or otherwise. Lack of knowledge by any bidders shall not constitute a cognizable defense against the legal effect thereof.

9. ADVERTISING: In submitting a bid, the Bidder agrees not to use the results therefrom as a part of any commercial advertising. The Bidder may not use the names, logos, or trademarks of the University, its employees, or affiliates without the prior written consent of the University.

10. ASSIGNMENT: Any contract or purchase order issued pursuant to this Invitation to Bid and the monies which may become due thereunder are not assignable, except with the prior written approval of the University of Central Florida. Under no circumstances shall the Bidder assign to a third party any right or obligation of the Bidder pursuant to any contract or purchase order resulting from this Invitation to Bid without prior written consent of the University. If the Bidder is, or during the term of this Invitation to Bid or during the term of any contract or purchase order resulting from this ITB, becomes an individual on the payroll of the State of Florida, the Bidder represents that he or she has complied with all applicable provisions of the Florida Statutes and Florida Administrative Code regarding outside or dual employment and compensation.

11. FACILITIES: The University reserves the right to inspect the Bidder's facilities at any time with prior notice.

12. PUBLIC RECORDS: Any contract or purchase order issued pursuant to this Invitation to Bid may be canceled unilaterally by the University for refusal by the Bidder to allow public access to all papers, documents, letters or other material subject to the provisions of Chapter 119, Florida Statutes, and made or received by the Bidder in conjunction herewith or any contract or purchase order issued pursuant to this Invitation to Bid.

13. RECORDS: The Bidder agrees to keep and maintain separate and independent records, in accordance with generally accepted accounting principles, devoted exclusively to its obligations and activities pursuant to a contract or purchase order issued pursuant to this Invitation to Bid. Such records (including books, ledgers, journals, and accounts) shall contain all entries reflecting the business operations under a contract or purchase order issued pursuant to this Invitation to Bid. The University or its authorized agent shall have the right to audit and inspect such records from time to time during the term of a contract or purchase order issued pursuant to this Invitation to Bid, upon reasonable notice to the Bidder.

14. METHOD OF ORDERING: Orders shall be processed only upon receipt of an authorized purchase order issued by University of Central Florida or University of Central Florida Visa Procurement Card (if applicable). All orders shall be initiated on an as-needed basis throughout the term of the contract. Orders shall be promptly filled and delivered. Any item or items received that do not meet specifications or duplicate shipments received will be returned at the Supplier's expense.

Note: Any and all special conditions and specifications attached hereto which vary from these general conditions shall have precedence.

Invitation to Bid Acknowledgment Form (revised 3/12/20)

Definitions:

Addendum – Written or graphic instruments issued prior to the date for opening of bids, which modify or interpret the solicitation documents by additions, deletions, corrections or clarifications.

Extension – A one-time (not to exceed 12 months) increase in the time allowed for the contract period in lieu of or after all renewals are exhausted.

FOB Destination – Free on board at destination; title changes hands from Supplier to purchaser at the destination of the shipment; Supplier owns goods in transit and files any claims. Payment of freight charges is determined by contract terms.

Invitation to Bid (ITB) – A written solicitation for competitive bids, advertised to the general public with a defined opening date. Specifications are clearly defined to the point that any interested company will be able to submit a bid for the exact item/service needed. This solicitation is generally required for acquisitions exceeding the established bid limit. Award is based on lowest priced bid.

May, Should – Indicates something that is not mandatory, but permissible, recommended, or desirable.

Minor Irregularities – Irregularities that have no adverse effect on UCF's interest will not affect the amount of the ITB and will not give a Respondent an advantage or benefit not enjoyed by another Respondent.

Must, Shall, Will – The words "must," "shall," or "will" are equivalent and indicate mandatory requirements or conditions.

Purchase Order/Contract – The Purchase Order (PO) or other form or format provided to the awarded Respondent(s) that UCF uses to make a purchase under the contract term, which includes a formal written PO, electronic PO, Procurement Card (PCard), or any other means authorized by Procurement Services and that incorporates the requirements and conditions listed in the Bid.

Renewal – Contracting with the same contractor for an additional period of time after the initial contract term, provided the original terms of the agreement specify an option to renew or the renewal is determined to be in the best interest of the university.

Respondent – For the purpose of this solicitation, any person, respondent, corporation or agency submitting a response to the Invitation to Bid or their duly authorized representative. The word Respondent, Vendor, Supplier, Contractor, and Offeror may be used interchangeably within the Invitation to Bid.

Response – The entirety of the Respondent's submitted bid response to the ITB, including any and all supplemental information submitted.

Responsible Respondent – Bidder who has the capability in all respects to perform fully the contract requirements, and the experience, integrity, perseverance, reliability, capacity, facilities, equipment, and credit which will assure good faith performance.

Responsive Respondent – Bidder who has submitted a bid that conforms in all material respects to the solicitation.

Sole Point of Contact – The Procurement Services representative or designee to whom Respondents shall address any questions regarding the solicitation or award process. The sole point of contact shall be the arbitrator of any dispute concerning performance of the Contract.

Successful Respondent – The firm or individual who is the recommended recipient of the award of a contract under this ITB (also synonymous with "Offeror," "Contractor" and "Supplier"). If a Respondent is a manufacturer, its certified dealers and resellers may also furnish products under the Contract; in choosing to do so, the dealers and resellers agree to honor the Contract and the term "Contractor" shall be deemed to refer to them. Unless awarded the Contract as a direct Respondent, however, dealers and resellers are not parties to the Contract, and the Respondent that certifies them shall be responsible for their actions and omissions.

UCF or University – University of Central Florida

Introduction

The University of Central Florida, Department of Civil, Environmental, and Construction Engineering would like to purchase services for installing a filtration system filled with designated sorption media for pollutant removal testing in a year or so, maintaining the filter, and decommissioning services after the completion of the testing (attachments 5 and 6).

1. POSTING OF BID TABULATIONS:
 - A. Bids will be opened at the Procurement Services Department at the assigned date and time identified in this ITB.
 - B. Bid tabulations will be posted at such time as the Procurement Services Department provides notice of intended decision or until 30 days after a public opening of the bids, whichever is earlier.
 - C. Notice of a decision or intended decision of award will be electronically posted for a period of 72 hours.
 - D. Failure to file a protest in accordance with BOG regulation 18.002 or failure to post the bond or other security as required in BOG regulation 18.003 shall constitute a waiver of protest proceedings.
2. BID OPENING: Bids will be received and opened on **July 15, 2022 at 3:00 p.m. EST** via Bonfire's Web Portal. For additional information, please refer to [Attachment 4](#). UCF shall in no way be responsible for or accept any proposals not uploaded prior to the closing date and time. Procurement Services will not extend the bid opening to accommodate Suppliers that did not discover the ITB early enough to place a bid. **BID DOCUMENTS CAN BE OBTAINED AT <https://procurement.ucf.edu/solicitations/>.**
3. ADDITIONAL INFORMATION & QUESTIONS: We encourage questions or comments which might aid in the improvement of our existing specifications. The University will not give verbal answers to inquiries regarding the specifications, or verbal instructions prior to or after award of the bid. A verbal statement regarding same by any person is non-binding. The university is not liable for any increased cost resulting from the bidder accepting verbal direction. All changes, if necessary, are made by written addendum to the bid.

Any explanation desired by Suppliers is to be requested of the Procurement Services Department in writing by **July 1, 2022 at 3:00 p.m. EST**. Inquiries are to be legible and concise and clearly identify the bidder who is submitting the inquiry. If an explanation is necessary, a reply shall be made in the form of a written addendum. Specifications, terms and conditions may not be changed except by formal written addendum, issued by UCF. Direct all inquiries/questions, preferably via email to:

Trinh Nguyen
University of Central Florida
Procurement Services Department
12424 Research Parkway, Suite 300
Orlando, Florida 32816-0975
Phone: 407-823-2661
Fax: 407-823-5551
trinh.nguyen@ucf.edu

4. DELIVERY: Specify delivery date after receipt of order in terms of days or weeks on bid sheet. Failure to do this may cause for rejection of the bid. Commodities delivery is to be made to UCF's Central Receiving location (University of Central Florida, Central Receiving Building 16E, 3540 East Perseus Loop, Orlando, FL 32816). When delivery is specified to a location other than the University's Central Receiving Department, the Supplier shall direct its carrier to telephone the University's Central Receiving Department before unloading.

FREIGHT TERMS: Unless otherwise specified, all shipments are to be shipped inside delivery, F.O.B. destination, with all transportation charges prepaid and title transferring to the university at time of delivery (Contractor pays and bears all freight related charges, owns goods in transit, and files any claims). Bid prices shall include all cartage, drayage, packing, etc. delivered to and unloaded at the receiving station at the site designated in the Invitation to Bid or purchase order and there received by the designated university personnel.

5. PARKING: The Contractor shall ensure that all Site access permit from the South Florida Water Management District for the filter installation needs to be acquired before the installation. The Contractor's vehicle(s) shall observe all parking rules and regulations. Failure to obtain site access permits, properly display them, and otherwise comply with all the District's permitted rules and regulations could result in the termination of the filtration installation.

6. **EMPLOYMENT OF ALIENS:** The employment of unauthorized aliens by any Contractor is considered a violation of Section 274A(e) of the Immigration and Nationality Act. If the contractor knowingly employs unauthorized aliens, such violation shall be cause for unilateral cancellation of the contract by the University without penalty to the University.
7. **AVAILABILITY OF FUNDS:** The obligations of the University under this award are subject to the availability of funds lawfully appropriated annually for its purposes by the Legislature of the State of Florida.
8. **AWARD:** Bids shall be awarded based on the lowest responsive and responsible bidder that meets specifications with consideration being given to the specific quality of the product, conformity to the specifications, suitability to the university's needs, delivery terms, qualifications, and past performance.
9. **REVISED QUANTITIES:** The University reserves the right to increase or decrease total quantities as necessary. The University may place additional orders for the same or modified scope of the commodities/services solicited under this ITB within 180 days after expiration of the contract resulting from this ITB. Total additional quantities/modified scope, if any, are unknown.
10. **CANCELLATION/TERMINATION:** UCF may terminate a contract resulting from this ITB without cause with thirty (30) days' advanced written notice to the Supplier. The parties to the contract resulting from this ITB may terminate that contract at any time by mutually consenting in writing. Either party may terminate the contract resulting from this ITB immediately for breach by the other that remains substantially uncured after thirty (30) days' advanced written notice to the breaching party, which notice describes the breach in detail sufficient to permit cure by the breaching party. The University shall be liable only for payment for services satisfactorily rendered or goods satisfactorily delivered and accepted from the date of commencement until the effective date of cancellation/termination. The thirty (30) days' advanced written notice shall start on the date sent out by UCF, e.g., date of email sent, date stamp on letter mailed, etc.
11. **TERM OF CONTRACT:** The contract resulting from this ITB, if any, shall commence on, or about July 25, 2022, and shall end upon successful completion of the site decommissioning. The University may renew/extend any Agreement, as mutually agreed to by both parties. Total renewals shall not exceed 5 years or twice the length of the original term, whichever is longer. An extension may not exceed 12 months or until completion of the competitive solicitation and award or protest, whichever is longer.
12. **CONTRACTOR INSURANCE:** All insurance shall be procured from companies authorized to do business in the State of Florida, with a minimum of A.M. Best rating of A, or equivalent. Proof of coverage shall be provided by submitting to the University's Risk Management Office a certificate or certificates, evidencing the existence thereof or binders and shall be delivered within fifteen (15) days of the tentative award date of the Contract. In the event a binder is delivered, it shall be replaced within thirty (30) days by a certificate in lieu thereto. A renewal certificate

shall be delivered to the University's Risk Management Office at least thirty (30) days prior to the expiration date of each expiring policy.

1. The University, at its sole discretion, has the right to deviate from any of the insurance requirements herein. If the University decides to deviate from the insurance requirements stated herein, the University will inform the Supplier in writing.
2. **General Liability:** Supplier shall provide a Certificate of Insurance evidencing Commercial General Liability insurance coverage in force with minimum limits of \$1,000,000 (ONE MILLION DOLLARS) per Occurrence and \$2,000,000 (TWO MILLION DOLLARS) Aggregate. Upon acceptance and confirmation of coverage by the University and before beginning work, and at all times during the term of the contract, Supplier will maintain said General Liability insurance in force and shall provide the University with a Certificate of Insurance and Additional Insured Endorsement listing the University of Central Florida Board of Trustees as "Additional Insured." The Certificate will provide a minimum 30 days advanced notice to in the event of cancellation.
3. **Auto Liability:** If Supplier operates a vehicle on campus for commercial use in the performance of this Contract (i.e. deliveries, transport of employees, etc.), Supplier shall provide a Certificate of Insurance evidencing Auto Liability insurance with minimum \$1,000,000 (ONE MILLION DOLLARS) per Accident Combined Single Limit for Bodily Injury and Property Damage. Upon acceptance and confirmation of coverage by University and before beginning work, and at all times during the term of the contract, Supplier will maintain said Auto Liability insurance in force and provide University with a Certificate of Insurance listing the University of Central Florida Board of Trustees as "Additional Insured." The Certificate will provide a minimum 30 days advanced notice to University in the event of cancellation.
4. **Workers' Compensation:** Supplier shall provide a Certificate of Insurance evidencing Workers' Compensation coverage consistent with Florida Statute and Employer's liability no less than \$500,000 (FIVE HUNDRED THOUSAND DOLLARS) for Bodily Injury by accident, each accident, Bodily Injury by disease, each employee, and policy limit. Upon acceptance and confirmation of coverage by University and before beginning work, and at all times during the term of the contract, Supplier will maintain said Workers Compensation and Employer's Liability insurance in force and provide University with a current Certificate of Insurance. The Certificate will provide a minimum 30 days advanced notice to University in the event of cancellation.
5. **Certificates of Insurance:** The University of Central Florida Board of Trustees is to be listed as Additional Insured on all Certificates issued. Supplier shall send a copy of his/her Certificate of Insurance along with accompanying Additional Insured Endorsements naming the University of Central Florida Board of Trustees to the following address:

Email: RiskManagement@ucf.edu

13. **USE OF CONTRACT BY OTHER GOVERNMENT AGENCIES:** At the option of the Contractor/ Supplier, the use of the contract resulting from this ITB, if any, may be extended to other governmental agencies, including the State of Florida, its agencies, political subdivisions, counties, and cities.

Each governmental agency allowed by the Contractor/ Supplier to use the contract resulting from this ITB, if any, shall do so independent of any other governmental entity. Each agency shall be responsible for its own purchases and shall be liable only for goods or services ordered, received and accepted. No agency receives any liability by virtue of this bid and subsequent contract award.

14. **PUBLIC ENTITY CRIMES:** A person or affiliate who has been placed on Florida's Convicted Vendor List following a conviction for a public entity crime may not submit a bid on a contract to provide any goods or services to a public entity, may not submit a bid on a contract with a public entity for the construction or repair of a public building or public work, may not submit bids on leases of real property to a public entity, may not be awarded or perform work as a contractor, supplier, subcontractor, or consultant under a contract with any public entity, and may not transact business with any public entity in excess of the bid limit for that public entity for a period of thirty-six (36) months from the date of being placed on the Convicted Vendor List.

15. **FLORIDA PREFERENCE:** For purchases of tangible personal property, the Florida legislature has enacted economic development laws establishing certain conditions and circumstances which, when applicable, require the granting of price preferences to businesses whose principal place of business is the State of Florida. Pursuant to §287.084, Florida Statutes, award recommendations shall make appropriate adjustments to Resident Supplier pricing when considering solicitations from Bidders having a principal place of business outside the State of Florida. All Bidders must complete and submit Attachment 1 with the response to this solicitation. Failure to comply shall be considered non-responsive to the terms of this solicitation. Refer to <http://www.leg.state.fl.us/Statutes/index.cfm> or UCF Regulation 7.130 for additional information regarding this Statute and its applicability.
16. **IDENTICAL TIE BIDS:** When multiple responses that are equal in all respects are received, the University will give preference to responses that include commodities manufactured in the state, Florida businesses, or foreign manufacturers located in the state to determine the contract award, or, if these conditions do not exist, will use a coin toss.
17. **EQUAL OPPORTUNITY STATEMENT:** The State Universities have established equal opportunity practices which conform to both the spirit and the letter of all laws against discrimination and prohibit discrimination based on race, creed, color, sex, age, national origin, marital status or religion. To be considered for inclusion as a supplier under this agreement, the bidder commits to the following:
- A. The provisions of Executive Order 11246, September 24, 1996, and the rules, regulations, and relevant orders of the Secretary of Labor are applicable to each order placed against this agreement regardless of value.
 - B. If the bidder expects to receive \$10,000 in orders during the first 12 months of this agreement, a complete certificate of non-segregated facilities shall be included in the bid response. A sample certificate is attached as Attachment 2.
 - C. If the bidder expects to receive \$50,000 in orders during the first 12 months of this agreement and employs more than 50 people, standard form 100 (EEO-1) must be filed prior to March 1 of each year.
 - D. If the bidder expects to receive \$50,000 in orders during the first 12 months and employs more than 50 people, a written program for affirmative action compliance is to be maintained by the bidder, subject to review upon request by the user agencies of the contract resulting from this ITB.
18. **WORK FOR HIRE:** Any work specifically created for the University under an agreement resulting from this ITB by the Contractor or anyone working on behalf of the Contractor (the term Contractor shall encompass both) shall be considered a "work for hire." All designs, prints, paintings, artwork, sketches, etchings, drawings, writings, photographs, or any other work or material or property produced, developed or fabricated and any other property created hereunder, including all material incorporated therein and all preliminary or other copies thereof (the "Materials") shall become and remain the property of the University, and, unless otherwise specifically set forth herein, shall be considered specially ordered for the University as a "work made for hire," or, if for any reason held not to be a "work for hire":

The Contractor who created, produced, developed or fabricated the Materials hereunder (or under any contract resulting from this ITB) assigns all of his/her right, title and interest in the Materials to the University. The University shall own all right, title and interest in the Materials. The Contractor agrees upon request to execute any documents necessary to perfect the transfer of such title to the University. The Materials shall be to the University's satisfaction and are subject to the University's approval. The Contractor bears all risk of loss or damage to the Materials until the University has accepted delivery of the Materials. The University shall be entitled to return, at the Contractor's expense, any Materials which the University deems to be unsatisfactory. On or before completion of the Contractor's services hereunder, the Contractor must furnish the University with valid and adequate releases necessary for the unrestricted use of the Materials for advertising or trade purposes, including model and property releases relating to the Materials and releases from any persons whose names, voices or likenesses are incorporated or used in the Materials.

The Contractor hereby represents and warrants that (a) all applicable laws, rules and regulations have been complied with, (b) the Contractor is free and has full right to enter into this ITB and any contract resulting from this ITB, if any, and perform all of its obligations hereunder and under such contract, (c) the Materials may be used or

reproduced for advertising or trade purposes or any commercial purposes without violating any laws or the rights of any third parties and (d) no third party has any rights in, to, or arising out of, or in connection with the Materials, including without limitation any claims for fees, royalties or other payments. The Contractor agrees to indemnify and hold harmless the University of Central Florida Board of Trustees and those acting for or on its behalf, the State of Florida and the Florida Board of Governors and their respective officers, agents, employees and servants from and against any and all losses, claims, damages, expenses or liabilities of any kind, including court costs and attorneys' fees, resulting from or in any way, directly or indirectly, connected with (a) the performance or non-performance of the University's order by the Contractor, (b) the use or reproduction in any manner, whatsoever, or (c) any breach or alleged breach of any of the Contractor's agreements or representations and warranties herein or in any contract resulting from this ITB.

19. **AMENDMENTS:** No changes or amendments to an agreement resulting from this ITB are binding to the University unless made in legible writing that is signed by an attorney in the University's General Counsel's Office and an authorized UCF signatory. Contractor shall return an agreement resulting from this ITB to the University's Procurement Services Department at once with a written explanation if the agreement resulting from this ITB is not acceptable in its entirety.
20. **EXPORT CONTROL:** The parties shall comply with all applicable U.S. export control laws and regulations, including but not limited to the International Traffic in Arms Regulations (ITAR), 22 CFR Parts 120 through 130, the Export Administration Regulations (EAR), 15 CFR Parts 730 through 799 and/or other restrictions imposed by the Treasury Department's Office of Foreign Asset Controls (OFAC), in the performance of an agreement resulting from this ITB. The parties agree that no technology, related data or information will be exchanged or disseminated under such agreement nor any collaboration conducted pursuant to such agreement, which are export controlled pursuant to the export control laws of the United States, including the EAR and the ITAR and any other applicable regulations. The Parties agree that the Contractor will not provide the University with any ITAR or EAR restricted technology and/or related data, and that any ITAR or EAR restricted technologies and/or data produced in furtherance of the agreement resulting from this ITB, if any, will be in the exclusive possession of the Contractor and at no time will any export controlled technologies, related data, or information be intentionally or inadvertently transferred to the University, its facilities, labs, staff, researchers, employees, officers, agents, servants or students in the performance of that agreement.

If the Contractor wishes to disclose export controlled technology or technical data to the University, the Contractor will, prior to disclosing any information, technical data or source code that is subject to export controls under federal law, notify the University in writing that the material is export controlled and shall identify the controls that apply. The University shall have the right to decline or limit (a) the receipt of such information and (b) any task requiring receipt of such information. In the event the Contractor sends any such technical data or product that is subject to export control, without notice of the applicability of such export control, the University has the right to immediately terminate the agreement resulting from this ITB, if any. The Contractor understands and agrees that to the extent the Contractor's personnel have access to work or materials subject to U.S. export controls while on University property, such personnel will meet all federal export control regulatory requirements or have the appropriate U.S. government approval.

21. **FORCE MAJEURE:** No default, delay or failure to perform on the part of UCF or the Supplier shall be considered a default, delay or failure to perform otherwise chargeable, hereunder, if such default, delay or failure to perform is due to causes beyond the Supplier's or UCF's reasonable control including, but not limited to, strikes, lockouts, actions or inactions of governmental authorities, epidemics, pandemics, wars, embargoes, fires, earthquakes, acts of God, or default of common carrier. In the event of such default, delay or failure to perform due to causes beyond the Supplier's or UCF's reasonable control, any dates or times by which the parties are otherwise scheduled to perform shall be extended automatically for a period of time equal in duration to the time lost by reason of the cause beyond the reasonable control of the parties.
22. **INDEMNIFICATION:** The Supplier shall hold the University of Central Florida Board of Trustees and the University's officers, employees, agents and/or servants harmless and indemnify each of them against any and all liabilities, actions, damages, suits, proceedings, and judgments from claims arising or resulting from the acts or omissions of the Supplier, its employees, its agents or of others under the Supplier's control and supervision. If any part of a delivery to the University pursuant to an agreement resulting from this ITB, if any, is protected by any patent, copyright, trademark, other intellectual property right or other right, the Supplier also shall indemnify and hold harmless the University of Central Florida Board of Trustees and the University's officers, employees, agents and/or

servants from and against any and all liabilities, actions, damages, suits, proceedings and judgments from claims instituted or recovered against the University by any person or persons whomsoever on account of the University's use or sale of such article in violation of rights under such patent, copyright, trademark, other intellectual property right or other right.

23. INDEPENDENT CONTRACTOR: Each of the parties is an independent contractor and nothing contained herein shall constitute or designate any of the employees or agents of one party as employees or agents of the other party.
24. NO JOINT VENTURE: Nothing contained in an agreement resulting from this ITB, if any, shall be construed to create a joint venture, partnership, or other like relationship between the parties.
25. LEASED EQUIPMENT: The risk of loss or damage to leased equipment, goods or property shall not transfer to the University except as provided in §680.219, Florida Statutes. Any security interest in the leased equipment, goods or property granted to Contractor contrary to AGO 79-72 and AGO 80-9 is null and void. Limitation of remedies provisions, which are unconscionable under applicable Florida law, are void.
26. MATERIAL SAFETY DATA SHEET (MSDS): In compliance with Florida Statutes, Chapter 442, a Material Safety Data Sheet (MSDS) must accompany any applicable item delivered under an agreement resulting from this ITB, if any.
27. WAIVER/REMEDIES: No failure or delay by a party hereto to insist on the strict performance of any term of an agreement resulting from this ITB, if any, or to exercise any right or remedy consequent to a breach thereof, shall constitute a waiver of any breach or any subsequent breach of such term. No waiver of any breach hereunder shall affect or alter the remaining terms of such agreement, but every term of such agreement shall continue in full force and effect with respect to any other then-existing or subsequent breach thereof. The remedies provided in an agreement resulting from this ITB, if any, are cumulative and not exclusive of the remedies provided by law or in equity.
28. DISPOSITION OF BIDS; FLORIDA PUBLIC RECORDS LAW COMPLIANCE: All bids become the property of the State of Florida, and the State of Florida shall have the right to use all ideas, and/or adaptations of those ideas, contained in any bid received in response to this solicitation. Any parts of the bid or any other material(s) submitted to UCF with the bid that are copyrighted or expressly marked as "confidential," "proprietary," or "trade secret," will only be exempted from the "open records" disclosure requirements of Chapter 119, Florida Statutes if Florida law specifically recognizes these materials as exempt from disclosure. Thus, the mere designation as "confidential," "proprietary," or "trade secret" by a Supplier does not ensure that such materials will be exempt from disclosure. Suppliers must identify specifically any information contained in their bid which they consider confidential and/or proprietary and which they believe to be exempt from disclosure, citing specifically the applicable exemption law. A generic notation that information is "confidential" is not sufficient. Failure to provide a detailed explanation and justification including statutory citations and specific reference to your bid detailing what provisions, if any, the Supplier believes are exempt from disclosure, may result in the entire bid being subject to disclosure in accordance with Chapter 119 of the Florida Statutes. In the absence of a specific Florida statute exempting material from the public records law, UCF is legally obligated to produce any and all public records produced or received in the course of conducting university business, irrespective of any designation by the Supplier of those same records as "confidential," "proprietary," or "trade secret." The ultimate determination of whether a Supplier's claim of "confidential," "proprietary," or "trade secret" will support an exemption from disclosure will be made by UCF or, potentially, a court. UCF's selection or rejection of a bid will not affect this provision.
29. PUBLIC RECORDS, CONTRACT FOR SERVICES: COMPLIANCE WITH SECTION 119.0701, FS
IF THE CONTRACTOR HAS QUESTIONS REGARDING THE APPLICATION OF CHAPTER 119, FLORIDA STATUTES, TO THE CONTRACTOR'S DUTY TO PROVIDE PUBLIC RECORDS RELATING TO THIS CONTRACT, CONTACT THE CUSTODIAN OF PUBLIC RECORDS AT: Office of the General Counsel, (407)823-2482, gcounsel@ucf.edu, University Of Central Florida, 4365 Andromeda Loop N., Millican Hall, Suite 360, Orlando, FL 32816-0015.

PUBLIC RECORDS, CONTRACT FOR SERVICES

To the extent that the Contractor meets the definition of “contractor” under Section 119.0701, Florida Statutes, in addition to other contract requirements provided by law, the Contractor must comply with public records laws, including the following provisions of Section 119.0701, Florida Statutes:

1. Keep and maintain public records required by the public agency to perform the service.
2. Upon request from the public agency's custodian of public records, provide the public agency with a copy of the requested records or allow the records to be inspected or copied within a reasonable time at a cost that does not exceed the cost provided in this chapter or as otherwise provided by law.
3. Ensure that public records that are exempt or confidential and exempt from public records disclosure requirements are not disclosed except as authorized by law for the duration of the contract term and following completion of the contract if the contractor does not transfer the records to the public agency.
4. Upon completion of the contract, transfer, at no cost, to the public agency all public records in possession of the contractor or keep and maintain public records required by the public agency to perform the service. If the contractor transfers all public records to the public agency upon completion of the contract, the contractor shall destroy any duplicate public records that are exempt or confidential and exempt from public records disclosure requirements. If the contractor keeps and maintains public records upon completion of the contract, the contractor shall meet all applicable requirements for retaining public records. All records stored electronically must be provided to the public agency, upon request from the public agency's custodian of public records, in a format that is compatible with the information technology systems of the public agency.

A request to inspect or copy public records relating to a public agency's contract for services must be made directly to the public agency. If the public agency does not possess the requested records, the public agency shall immediately notify the contractor of the request, and the contractor must provide the records to the public agency or allow the records to be inspected or copied within a reasonable time.

If a contractor does not comply with the public agency's request for records, the public agency shall enforce the contract provisions in accordance with the contract.

This Contractor and any subcontractors shall abide by the requirements of 41 CFR §§ 60-1.4(a), 60-300.5(a), 60-741.5(a), and 29 CFR Part 471, Appendix A to Subpart A with respect to affirmative action program and posting requirements. These regulations prohibit discrimination against qualified individuals based on their status as protected veterans or individuals with disabilities and prohibit discrimination against all individuals based on their race, color, religion, sex, sexual orientation, gender identity, or national origin. Moreover, these regulations require that covered prime contractors and subcontractors take affirmative action to employ and advance in employment individuals without regard to race, color, religion, sex, sexual orientation, gender identity, national origin, protected veteran status, or physical or mental disability.

30. SOFTWARE RELATED PURCHASES: Licensor acknowledges that Licensee has a duty to maintain the privacy of student records, including without limitation education records as defined by the Family Educational Rights and Privacy Act (20 USC § 1232g; 34 CFR Part 99) (“FERPA”), and further acknowledges that as a contractor to whom Licensee has outsourced certain institutional services or functions:
 - A. Confidential information about Licensee’s students is contained in records provided to and maintained by Licensor, and Licensor will protect the privacy of all student education records to the fullest extent required of Licensee under FERPA;
 - B. Licensor is performing an institutional service or function that has been outsourced by Licensee and for which Licensee would otherwise use its employees;
 - C. Licensor is under the direct control of Licensee with respect to the use and maintenance of education records, as defined by FERPA;
 - D. Licensor is subject to all FERPA requirements governing the use and re-disclosure of personally identifiable information from education records, including without limitation the requirements of 34 CFR § 99.33(a);
 - E. Even in circumstances that might justify an exception under FERPA, Licensor may not disclose or re-disclose personally identifiable information unless Licensee has first authorized in writing such disclosure or re-disclosure; and
 - F. Licensor will not use any personally identifiable information acquired from Licensee for any purpose other than performing the services or function that are the subject of this agreement.

31. **SMOKE-FREE POLICY:** The University prohibits smoking on all university owned, operated, leased and/or controlled properties in order to maintain a healthy and safe environment for its faculty, staff, students, and visitors. Visit <http://www.ucf.edu/smokefree> for additional information.
32. **CONTACT WITH MINOR CHILDREN:** To the extent that the Supplier qualifies as a provider to the National Child Protection Act of 1993, as amended or as a service provider in accordance with applicable Florida law/statutes, who has direct contact with children receiving services or with adults who are developmentally disabled receiving services or who qualifies as a direct service provider of the elderly (as defined by Florida law/statutes), the Supplier hereby guarantees that the Supplier and/or anyone acting on the Supplier's behalf (including, but not limited to Supplier's employees, agents, subcontractors, etc.) has undergone/passed a Level II (two) background check with the State of Florida and hereby certifies that none of the Supplier's employees, agents, subcontractors and/or anyone else acting on the Supplier's behalf has any disqualifying offenses, including, but not limited to those listed in Section 435.04, Florida Statutes.
33. **REPORTING OF CHILD ABUSE:** The Supplier hereby expressly agrees to instruct its employees, agents, subcontractors and/or anyone else acting on the Supplier's behalf to report to the University of Central Florida police any instance of child abuse, abandonment, or neglect witnessed or learned about that occurred on University of Central Florida property or during an event or function sponsored by the University of Central Florida.
34. **PROCUREMENT RULES:**
- A. UCF has established for the purposes of this ITB that the words "shall," "must," or "will" are equivalent in this ITB and indicate a mandatory requirement or condition, the material deviation from which could be waived by UCF. UCF will, at UCF's sole discretion, determine whether a deviation is material. Any deviation found by UCF to be material shall result in the rejection of the bid.
 - B. The words "should" or "may" are equivalent in this ITB and indicate very desirable conditions or requirements but are permissive in nature. Deviation from, or omission of, such a desirable condition or requirement will not in and of itself cause automatic rejection of a bid, but may result in the bid being considered as not in the best interest of UCF. UCF will, at UCF's sole discretion, determine whether a bid is considered as not in the best interest of UCF and may or may not reject the bid, all at UCF's sole discretion.
 - C. The Respondent is solely responsible for the accuracy and completeness of its bid. The Respondent's errors or omissions, if any, are solely at the risk of the Respondent and may be grounds for rejection of the bid and shall give UCF the right to reject the bid, at UCF's sole discretion.
35. **SECURE HANDLING OF UCF DATA:** The University requires Suppliers and other third parties to review, accept, and integrate secure data handling requirements as part of any contract, agreement, or Service Level Agreement ("SLA") that involves the storage, transmission, processing, or collection of UCF data, or access to UCF data, by the Supplier. This Agreement is intended to ensure that UCF's security and compliance requirements are outlined and followed by the Supplier. Additional agreements may be required depending on the data involved. Visit <http://www.infosec.ucf.edu/vrm> for additional information.
36. **BACKGROUND CHECKS:** The Contractor assumes all liability arising out of, and is solely responsible for, conducting background checks for all of the Contractor's employees, agents, or independent contractors. The Contractor shall provide background checks for all of the contractor's non-temporary employees, agents, or independent contractors working at UCF and shall ensure that all hires have been cleared before placement at the University. Temporary employees hired through a temporary staffing agency shall require the background checks listed herein, and Contractor may satisfy this requirement by conducting the background checks directly or having a contract with the temporary staffing agency that incorporates the same requirements.

Convictions discovered in the background check will be reviewed by Contractor's Loss Prevention and/or Human Resources department. Consideration may be given to the person's relationship to the job, how long ago the conviction occurred, the potential risk posed to employees, customers, students, and the University and any other circumstances deemed relevant to the final determination of whether to employ or retain the person. Conviction information will be maintained by Contractor as confidential.

Background checks shall include, at a minimum, the following items:

A State of Florida Level I Background Check (Level 1): Which consists of criminal history background check inclusive of a search of the following:

- National Sex Offenders Registry
- Statewide criminal history background check through the Florida Department of Law Enforcement (FDLE)
- Local criminal records check through local law enforcement agencies

Certification that such personnel, agents, and subcontractors have satisfactorily completed a background check equivalent to Level 1 Background Check standards must be furnished to the University.

Depending on the nature of the position or duties required, hiring officials may require the temporary employment agency and/or contractors to provide evidence of additional levels of background checks performed pursuant to State of Florida Level 2 background check standards prior to commencement of work.

37. E-VERIFY: All terms defined in §448.095, Fla. Stat., are adopted and incorporated into this provision. Pursuant to §448.095, Fla. Stat., Vendor certifies that it is registered with and uses the U.S. Department of Homeland Security's E-Verify system to verify the employment eligibility of all of Vendor's employees hired by the Vendor during the term of this Agreement and/or while performing work or providing services for UCF. Vendor shall require that all subcontractors performing work or providing services on behalf of Vendor for UCF also comply with the requirements of §448.095, Fla. Stat and utilize the E-Verify system to verify employment eligibility of all employees hired by subcontractor. The Vendor shall require for the subcontractor to provide to Vendor an affidavit stating that the subcontractor does not employ, contract with or subcontract with an unauthorized alien. Vendor shall maintain a copy of such affidavit for the duration of the Agreement. UCF may terminate this Agreement immediately upon notice to Vendor for any violation of this provision. A Vendor whose contract is terminated pursuant to this paragraph is liable for additional costs incurred by UCF due to the termination of the Agreement.
38. COVID-19 POLICY COMPLIANCE: Pursuant to UCF's Emergency COVID-19 Return Policy (<https://policies.ucf.edu/documents/PolicyEmergencyCOVIDReturnPolicy.pdf>), the University of Central Florida requires vendors/contractors and employees to wear a mask or facial covering when indoors in all common indoor areas with other people present even if physically distant, all enclosed spaces with other people present, and when outdoors. In addition, before coming to campus, you are required to complete the COVID self-checker questionnaire (https://ucf.service-now.com/self_checker?id=public) and be cleared each day you plan on coming to campus. Violation of this policy may result in immediate removal from campus. Repeat offenses may result in termination of contract. Vendor agrees to follow all applicable UCF COVID policies as may be developed and updated. For additional information regarding COVID and vendors/contractors, please visit <https://www.ucf.edu/coronavirus/resources-for-visitors-vendors-contractors/>.

BID SHEET – Part 1
Construction / Equipment Installation

Line Item	Description	Units	Qty	Unit Price	Price
1	Cut/Fill Earthwork to construct the 4 cells	yd ³	220		
2	Supply/Install Pond Liner, 40 mil HDPE min., w/ anchor trench	ft ²	6814		
3	Supply/Install 4" Pipe Boot for pond liners	ea	4		
4	Supply/Install 4" perforated drainpipe in all Cells	ft	475		
5	Supply/Install 4" drainpipes from cells to Drainage Control Boxes	ft	947		
6	Supply/Install Drainage Control Boxes (4" inlets)	ea	4		
7	Supply/Install 8" drainpipe to canal outlet	ft	60		
8	Supply/Install #57 double washed gravel in cells over drainpipes	yd ³	40		
9	Supply/Install geotextile porous fabric over gravel in all cells	ft ²	2200		
10	Supply/Install CPS media – See mixing recipe	yd ³	100		
11	Supply/Install ZIPGEM-2 media – See mixing recipe	yd ³	100		
12	Supply/Install 30 gpm submersible pumps /w 1" mesh screen enclosure with check valve in the C-23 Canal	ea	4		
13	Supply/Install "No Anchorage" warning posts by pumps	ea	2		
14	Supply/Install Pumps Control Panel /w pump controllers	ea	1		
15	Supply/Install Cellular Control Module in Pump Control Panel for remote pump control	ea	1		
16	Install temporary power pole with electric meter base	ea	1		
17	FP&L Service Connection Fee	ea	1		
18	Install buried power line from meter pole to Pump Control Panel.	ft	30		
19	Supply/Install 2" PVC pipelines from pumps to inlet bubblers	ft	1940		
20	2" flowmeter on inflow line to each cell	ea	4		
21	2" air release valve on inflow line to each cell	ea	4		
22	Supply/Install 8 Inlet bubblers with rip rap energy dispensing	ea	8		
23	Power Supply to Eurika Panel	ft	200		
24	Install Stilling Wells in each cell with Float Controls	ea	4		
25	Supply/Install Pressure Transducers in cells 2, 3, 4	ea	3		
26	System Startup and Performance Certification by Contractor	ea	1		
27	Routine Site Maintenance (mowing at least 5 time/year)	yrs	1		
28	Setup and pay monthly electric bill (will be < \$500/month)	month	12		
29	Setup and pay monthly cellular service for remote pumps control module	month	12		
30	Obtain "Temporary Access Permit" from the SFWMD	ea	1		

Part 1 Total \$ _____

BID SHEET – Part 2
Site Decommissioning after Project Completion in 1 to 2 Years

Line Item	Description	Units	Qty	Unit Price	Price
1	Equipment removal (UCF to retain all monitoring equipment, but the contractor can retain remaining equipment, such as the pumps, control panel, and power pole.	ea	1		
2	Remove and depose of all exposed materials such as pipes, wires, and electrical conduits that are within 0.5 feet of the native ground surface.	ea	1		
3	Remove and dispose of all liner material that is within 0.5' of the native ground surface	ft ²	1200		
4	Breach liners in bottom of ponds in four places in each pond	ea	16		
5	Media and gravel to be covered at least 1' deep with the soil in the pond berms and graded with 6:1 side-slopes	yd ³	200		
6	After final grading, mulch and seed the exposed soil.	ft ²	6000		

Part 2 Total \$ _____

Total for Part 1 and Part 2: \$ _____

Specifications Requirements:

Please reference Attachment 5, Scope of Work and Design Specifications Report, that describes the scope of work to be completed along with detailed specifications. Attachment 6, Design Drawing, provides the design drawings for all the various project components.

Pricing:

- The total price must include the installation of the filter to be completed within 35 days from the start date of award (receiving the purchase order from UCF).
- The total price must include 1 year warranty to cover the operation of the pumping systems to include pipes/valves.

Total Cost: \$ _____

Qualification Requirements:

Vendor must have previous experience in all aspects of the project as detailed in Attachments 5 and 6, and extensive experience in earthen ponds, impervious liners, pumping stations, and control panel installation.

Vendor must provide:

QUALIFICATION OF BIDDERS: This bid will be awarded only to a responsible bidder, qualified by experience and in a financial position to provide the items specified. In order to facilitate the prompt award of this bid, the bidder is to submit with the Bid:

- Contractor must have a minimum of 5 years of experience and provide documentation (i.e. letter, memo stating their experience with services described in Attachment 5 with like size and complexity as the scope of this bid. Documentation must include the following:
 - Provide a List of at least 3 contracts with brief descriptions of similar work satisfactorily completed with location, dates of contracts, dollar value of contract, names, address of owners and email address.

- Copy of license to do business in the State of Florida.
- Provide a good plan to show how the filter can be installed within 35 days after the receipt of the order and maintained till the decommissioning service is required.

Does your bid meet our specifications and qualification exactly? ___Yes ___No

If not, please detail how your bid meets or exceeds the specifications of the required item(s) and provide proof that verifies your claim.

Prices quoted are good for at least _____ days following bid opening.

Delivery will be _____ days after receipt of order.

F.O.B. delivered to UCF

Payment terms: _____.

I certify that this bid is made without prior understanding, agreement or connection with any corporation, firm, or person submitting a bid for the same materials, supplies or equipment and is in all respects fair and without collusion or fraud. The following information, including an authorized representative signature and witness, is required to be submitted with your bid in order to be considered for evaluation and award. The person signing below acknowledges and agrees with all proposed information as submitted and has the authorization of the said company to enter into a contractual agreement with the University for the purposes as proposed and as described herein. Please print below unless where a signature is required.

COMPANY NAME

AUTHORIZED SIGNATURE

MAILING ADDRESS

PRINTED NAME

CITY, STATE, ZIP CODE

TITLE

(_____)_____
PHONE NUMBER

(_____)_____
FAX NUMBER

EMAIL ADDRESS

ATTACHMENT 1

BIDDER'S STATEMENT OF PRINCIPAL PLACE OF BUSINESS
(Must be completed & submitted with each competitive solicitation)

Name of Bidder: _____

Identify the state in which the Bidder has its principal place of business: _____

Proceed as follow: IF your principal place of business above is located within the State of Florida, the Bidder must sign below and attach to your solicitation. No further action is required. IF your principal place of business is outside of the State of Florida, the following must be completed by an attorney and returned with your solicitation. Failure to comply may be considered to be non-responsive to this solicitation.

OPINION OF OUT-OF-STATE BIDDER'S ATTORNEY ON BIDDING PREFERENCES
(To be completed by the Attorney for an Out-of-State Bidder)

NOTICE: Section 287.084(2), Florida Statutes, provides that "a Supplier whose principal place of business is outside this state must accompany any written bid, proposal, or reply documents with a written opinion of an attorney at law licensed to practice law in that foreign state, as to the preferences, if any or none, granted by the law of that state [or political subdivision thereof] to its own business entities whose principal places of business are in that foreign state in the letting of any or all public contracts."

LEGAL OPINION ABOUT STATE BIDDING PREFERENCES
(Please Select One)

_____ The Bidder's principal place of business is in the State of _____ and it is my legal opinion that the laws of that state **do not grant a preference** in the letting of any or all public contracts to business entities whose principal places of business are in that state.

_____ The Bidder's principal place of business is in the State of _____ and it is my legal opinion that the laws of that state **grant the following preference(s)** in the letting of any or all public contracts to business entities whose principal places of business are in that state: [Please describe applicable preference(s) and identify applicable state law(s)]:

LEGAL OPINION ABOUT POLITICAL SUBDIVISION BIDDING PREFERENCES
(Please Select One)

_____ The Bidder's principal place of business is in the political subdivision of _____ and it is my legal opinion that the laws of that political subdivision **do not grant a preference** in the letting of any or all public contracts to business entities whose principal places of business are in that political subdivision.

_____ The Bidder's principal place of business is in the political subdivision of _____ and the laws of that political subdivision **grant the following preference(s)** in the letting of any or all public contracts to business entities whose principal places of business are in that political subdivision: [Please describe applicable preference(s) and identify applicable authority granting the preference(s)]:

Signature of Out-of-state Bidder's Attorney: _____

Printed Name of Out-of-state Bidder's Attorney: _____

Address of Out-of-state Bidder's Attorney: _____

Telephone Number of Out-of-state Bidder's Attorney: (_____) _____ - _____

Email Address of Out-of-state Bidder's Attorney: _____

Attorney's State of Bar Admission: _____

Bidder's Printed Name: _____

Signature _____

ATTACHMENT 2

CERTIFICATE OF NON-SEGREGATED FACILITIES

We, _____ certify to the University of Central Florida that we do not and will not maintain or provide for our employees any segregated facilities at any of our establishments, and that we do not and will not permit our employees to perform their services, under our control, where segregated facilities are maintained. We understand and agree that a breach of this certification is a violation of the Equal Opportunity clause required by Executive Order 11246, as amended.

As used in this certification, the term "segregated facilities" means any waiting rooms, work areas, rest rooms and wash room, restaurants and other eating areas, time clocks, locker rooms and other storage or dressing areas, parking lots, drinking fountains, recreation or entertainment areas, transportation and housing facilities provided for employees which are segregated by explicit directive or are in fact segregated on the basis of race, creed, color or national origin, because of habit, local custom or otherwise.

We, further, agree that (except where we have obtained identical certifications from offered subcontractors for specific time periods) we will obtain identical certifications from offered subcontractors prior to the award of subcontracts exceeding \$10,000 which are not exempt from the provisions of the Equal Opportunity Clause; that we will retain such certification in our files; and that we will forward the following notice to such offered subcontractors (except where the offered subcontractors have submitted certifications for specific time periods).

NOTE TO PROSPECTIVE SUBCONTRACTORS ON REQUIREMENTS FOR CERTIFICATIONS OF NON-SEGREGATED FACILITIES: A Certificate of Non-segregated Facilities, as required by the 9 May 1967 order on Elimination of Segregated Facilities, by the Secretary of Labor (32 Fed. Reg. 7439, 19 May 1967), must be submitted prior to the award of a subcontract exceeding \$10,000 which is not exempt from the provisions of the Equal Opportunity clause. The certification may be submitted either for each subcontract or for all subcontracts during a period (i.e., quarterly, semiannually, or annually).

The Contractor and subcontractors shall abide by the requirements of 41 CFR, Section 60-1.4(a), 60-300.5(a), 60-741.5(a), and 29 CFR Part 471, Appendix A to Subpart A with respect to affirmative action program and posting requirements. These regulations prohibit discrimination against qualified individuals based on their status as protected veterans or individuals with disabilities and prohibit discrimination against all individuals based on their race, color, religion, sex, sexual orientation, gender identity, or national origin. Moreover, these regulations require that covered prime contractors and subcontractors take affirmative action to employ and advance in employment individuals without regard to race, color, religion, sex, sexual orientation, gender identity, national origin, protected veteran status, or physical or mental disability.

NOTE: Whoever knowingly and willfully makes any false, fictitious, or fraudulent representation may be liable to criminal prosecution under 18 U.S.C. 1001.

ATTACHMENT 2

CERTIFICATE OF NON-SEGREGATED FACILITIES SUBPART – CONTRACTOR'S AGREEMENTS

SEC. 202. Except in contracts exempted in accordance with Section 204 of this Order, all Government contracting agencies shall include in every Government contract hereafter entered into the following provisions:

During the performance of this contract, the contractor agrees as follows:

- (1) The contractor will not discriminate against any employee or applicant for employment because of race, color, religion, sex, sexual orientation, gender identity, or national origin. The contractor will take affirmative action to ensure that applicants are employed, and that employees are treated during employment, without regard to their race, color, religion, sex, sexual orientation, gender identity, or national origin. Such action shall include, but not be limited to the following: employment, upgrading demotion, or transfer; recruitment or recruitment advertising; layoff or termination; rates of pay or other forms of compensation; and selection for training, including apprenticeship. The contractor agrees to post in conspicuous places, available to employees and applicants for employment, notices to be provided by the contracting officer setting forth the provisions of this nondiscrimination clause.
- (2) The contractor will, in all solicitations or advertisements for employees placed by or on behalf of the contractor, state that all qualified applicants will receive consideration for employment without regard to race, color, religion, sex, sexual orientation, gender identity, or national origin.
- (3) The contractor will send to each labor union or representative of workers with which the contractor has a collective bargaining agreement or other contract or understanding, a notice, to be provided by the agency contracting officer, advising the labor union or worker's representative of the contractor's commitments under Section 202 of Executive Order No. 11246 of September 24, 1965, and shall post copies of notice in conspicuous places available to employees and applicants for employment.
- (4) The contractor will comply with all provisions of Executive Order No. 11246 of September 24, 1965 and of the rules, regulations, and relevant orders of the Secretary of Labor.
- (5) The contractor will furnish all information and reports required by Executive Order No. 11246 of September 24, 1965, and by the rules, regulations, and orders of the Secretary of Labor, or pursuant thereto, and will permit access to his books, records, and accounts by the contracting agency and the Secretary of Labor for purposes of investigation to ascertain compliance with such rules, regulations and orders.
- (6) In the event of the contractor's noncompliance with the nondiscrimination clauses of this contract or with any of such rules, regulations, or orders, this contract may be canceled, terminated, or suspended in whole or in part and the contractor may be declared ineligible for further Government contracts in accordance with procedures authorized in Executive Order No. 11246 of September 24, 1965, and such other sanctions may be imposed and remedies invoiced as provided in Executive Order No. 11246 of September 24, 1965, or by rule, regulation, or order of the Secretary of Labor, or as otherwise provided by law.
- (7) The contractor will include the provision of Paragraphs (1) through (7) in every subcontract or purchase order unless exempted by rules, regulations, or orders of the Secretary of Labor issued pursuant to Section 204 of Executive Order No. 11246 of September 24, 1965, so that such provisions will be binding upon each subcontractor or Supplier. The contractor will take such action with respect to any subcontract or purchase orders the contracting agency may direct as a means of enforcing such provisions including sanctions for noncompliance. Provided, however, that in the event the contractor becomes involved in, or is threatened with, litigation with a subcontractor or Supplier as a result of such direction by the contracting agency, the contractor may request the United States to enter into such litigation to protect the interest of the United States.

SEC. 402 Affirmative Action for Disabled Veterans and Veterans of the Vietnam Era:

- (1) The contractor agrees to comply with the affirmative action clause and regulation published by the US Department of Labor implementing Section 402 of the Vietnam Era Veteran's Readjustment Assistance Act of 1974, as amended, and Executive Order 11701, which are incorporated in this certificate by reference.

Company: _____

Authorized Representative's Name: _____

Authorized Representative's Signature: _____

Date: _____

ATTACHMENT 3

COMPLIANCE AND CERTIFICATION OF GOOD STANDINGS

The parties shall at all times comply with all applicable ordinances, laws, rules and regulations of local, state and federal governments, or any political subdivision or agency, or authority or commission thereof, which may have jurisdiction to pass laws, ordinances, or make and enforce rules and regulations with respect to the parties.

Suppliers shall certify below that they are in good standings to conduct business in the State of Florida. **The awardee of any contract resulting from this solicitation shall forward a certification of good standing, upon request of UCF.** Noncompliance with this provision may constitute rejection of proposal or termination of a contract at UCF's sole discretion.

CERTIFICATION

I certify that the company submitting an offer under this solicitation is in compliance with all applicable laws to conduct business in the State of Florida, is in good standings and will provide a certificate of good standings from the state of residence prior to initiating any performance under any contract resulting from this solicitation.

Company: _____

Authorized Representative's Name: _____

Authorized Representative's Signature: _____

Date: _____

ATTACHMENT 4

Submission Instructions for Suppliers

Please follow these instructions to submit via our Public Portal.

1. Prepare your submission materials:

Requested Information

Name	Type	# Files	Requirement
Proposal	File Type: Any	Multiple	Required

Requested Documents:

Please note the type and number of files allowed. The maximum upload file size is 1000 MB.

Please do not embed any documents within your uploaded files, as they will not be accessible or evaluated.

2. Upload your submission at:

<https://ucfprocurement.bonfirehub.com/opportunities/69636>

Your submission must be uploaded, submitted, and finalized prior to the Closing Time of **July 15, 2022 3:00 PM EDT**. We strongly recommend that you give yourself sufficient time and **at least ONE (1) day** before Closing Time to begin the uploading process and to finalize your submission.

Important Notes:

Each item of Requested Information will only be visible after the Closing Time.

Uploading large documents may take significant time, depending on the size of the file(s) and your Internet connection speed.

You will receive an email confirmation receipt with a unique confirmation number once you finalize your submission.

Minimum system requirements: Internet Explorer 11, Microsoft Edge, Google Chrome, or Mozilla Firefox. Javascript must be enabled. Browser cookies must be enabled.

Need Help?

University of Central Florida Procurement Services uses a Bonfire portal for accepting and evaluating proposals digitally. Please contact Bonfire at Support@GoBonfire.com for technical questions related to your submission. You can also visit their help forum at <https://bonfirehub.zendesk.com/hc>

Attachment 5

Scope of Work and Design Specifications Report

For Project Entitled
Installation of Experimental Beds for Filtration Media and Decommission

University of Central Florida

Introduction and System Description

This design and specifications report is for the University of Central Florida's (UCF's) grant to construct a demonstration project for a bio-sorption activated media filtration treatment system to reduce nutrients and algae mass in the C-23 Canal. The project site is located just east of I-95 on the south side of the C-23 canal within the South Florida Water Management District's (SFWMD's) right-of-way (Sheet 1). The proposed system will extract water from the C-23 canal using four 30-gpm (0.043 MGD) submersible pumps and deliver it to four (22'W x 43.5'L top of berm dimension) infiltration cells (Sheets 2, 4a, and 4b). Each cell will have a dedicated pump and float controls to maintain a 6-inch water depth over the media within ± 2 inches. A flowmeter will be placed on each cell's inlet pipeline and will be able to be read remotely via a cellular telemetry system. This telemetry system will also provide remote viewing of the infiltration pond water levels, flow volumes to and from the ponds, real-time water quality data, as well as providing the ability to turn pumps on or off remotely. The cells will be 4 feet deep and based on cut-fill estimates will have an average berm height above natural grade of 1.62 feet with a top of berm elevation of 33.0 feet (NGVD29). The perimeter berm will have 3:1 exterior and 1:1 interior side-slopes. The canal water will be delivered into each cell via multiple energy dissipating bubbler inlets to prevent scouring of the media. This design and specifications report covers the entire system design that will be placed within the SFWMD easement. Please note that a 40-foot buffer from the top of the C-23 canal berm will be kept unobstructed as seen in the design drawings.

Cells 1 and 2 will have CPS media with a thickness of 2 feet while cells 3 and 4 will have ZIPGEM media with a thickness of 2 feet (see media specifications below). The media will be underlain with about 6 inches of gravel cover with a permeable geo-textural fabric sheet. Embedded in the gravel will be three 4" perforated plastic drainpipes to collect and deliver the infiltrated (treated) water back to the C-23 canal approximately 200 feet east (downstream) from where water will be extracted from the canal. This separation is necessary to reduce recycling of treated water within the canal during low flow periods. Low flow periods occur about 50% of the time, based on flow data from the S-97 structure located approximately 3.3 miles downstream (east) of the site. Water levels in the C-23 range from about 15.5 to 23 feet (NGVD29) as shown in (Figure 1), and the elevation of top of the cells' berm will be about 33.0 feet (NGVD29) (Sheets 4a and 4b), which means there will always be sufficient head through the media to ensure design flows are maintained. Each of the outlets from the cell underdrain systems will be piped to a drainage control box (Sheets 4a, 4b, and 6) that will allow the outlet head of the cell to be set and also allows a water quality and depth pressure probe to be placed in it. These probes will be connected to a telemetry panel for continuous and remote monitoring

of various water quality parameters and waterdepth, which can be converted to flow via the “v” notch weir plates. A fifth water quality probe will be placed in the #1 cell to continuously monitor the inflow canal water. During site visits, grabs samples will be collected in the ponds (canal water) and from the drainage control boxes to verify the data from the water quality probes. Using the drainage control box outlet flow measurements, the inflow pipe flowmeter readings, and the site’s rain gage, a complete water balance for each cell can be calculated. Then combining the water quality and flow data, the treatment efficiency and total nutrient (nitrogen and phosphorus) loads removed within each cell will be calculated daily over the duration of the project.

Design and Specifications for the Water Delivery System Components

Canal Pumping System

It is purposed to use four (4) individual low head “chopper” style electric submersible pumps be installed as shown in Sheets 2 and 9. Each pump is to have the following specifications: 30 gpm flow capacity with optimal efficiencies between 15 to 25 feet of total dynamic head (TDH) and a single-phase 240VAC electric motor. The pumps will maintain a water depth of 6-inches over the media in the ponds by using float switches mounted in stilling wells in each pond (Sheets 2, 8, 9,& 10) that are wired to the pump control panel (Sheet 12). Example wiring of the Electrical Control Panel for the pumps is provided in Sheet 12. All pumps, pipes, valves, and electrical components must meet SFWMD minimum specifications.

The pumps are to be mounted on a slide (Sheet 9) such that their inlet is located at or below the elevation of 12.5 feet (17 feet below top of bank @ 31.5 feet-NGVD29) and at least 12 inches from the canal side slope or the bottom of the canal. Pumps are to be placed as close as possible to each other along the canal bank. Two non-corrosive (stainless steel or PVC over treated mounting post) navigation avoidance posts at least 8” in diameter are to be installed as shown on Sheets 2 and 9 with a “Do Not Anchor” warning sign on each post. The pump discharge pipe (2-inch Schedule 40 PVC or equivalent) is to have a disconnect flange just before where the horizontal pipe is buried into the canal bank (Sheet 9). The pipes in the berm are to be buried to a depth of at least 24 inches (Sheet 9). The power cable from the control panel can be buried with the pipes but must be in an armored and anchored in conduit between the pump and the buried pipe. A 2-inch check-valve must be installed on the discharge pipe of each pump (Sheets 9 and 11) to prevent backflow.

Piping Layout for Water Delivery to Ponds

All pipelines from the pumps to the ponds is to be Schedule 40 2-inch diameter PVC or equivalent. Sheets 2, 4, and 9 show the general layout of the pipelines to the ponds. Pipelines outside of the ponds are to be buried to a depth of at least 24 inches. Within the ponds the pipes are to be laid on top of media. Due to heavy vehicular traffic all PVC pipes must have cemented joints.

The flowmeters for all of the pipelines from each pump will be located where the inlet pipes cross over the top of the southern berms (Sheets 7, 8a, and 8b). An air release valve is to be placed on the inlet pipe as shown in Sheet 7.

Energy Dissipating Inflow Ports in Ponds

Each infiltration pond shall have two energy dissipating inflow ports to provide even distribution of the canal water within the ponds while also preventing any erosion/disturbance of the media (Sheets 8a, 8b, and 9). The blowup of the proposed inflow port is shown on Sheet 9 where a 3-foot diameter 6-inch-high pile of small rip rap will be placed on top of permeable fabric around the riser pipe to maximize energy dissipation. Besides dissipating energy to prevent erosion, this configuration also prevents backflow from the ponds toward the pumps, even if a check valve failure were to occur.

Flowmeters and Air Release Valves

As indicated above, each pipeline into the infiltration ponds will have its own flowmeter. It is recommended to use 2-inch flowmeters with accumulative flow volume reading visible on each flowmeter, as well as it being able to send a wired digital/pulse signal to the Eureka Telemetry Panel, so that the flowmeter readings can be read remotely at any time. The flowmeters must be placed at least ten pipe diameter lengths from anything that can cause turbulence, such as fittings (Sheet 7). An air release valve is to be placed on the inlet pipe as shown in Sheet 7.

Water Depth Transducers

Each infiltration pond will have a water level sensor or pressure transducer located within a stilling well located in its NE corner approximately three feet in from the bottom of the perimeter berm. Sheets 2, 8a, 8b, 9, and 10 show the location and a blowup of the recommended 10-inch diameter PVC stilling well that is perforated with numerous ¼-inch holes including its bottom to allow water to equilibrate between the pond and inside the well (Sheet 9 and 10). To prevent media from flowing through the ¼ -inch holes, the outside of the well pipe should be wrapped with a screening material. The stilling well will be installed 6 inches into the media (see Sheets 9 and 10) so that the depth (pressure) sensor can be located below the top of the media. The pressure sensor shall have a depth range of at least 0 to 2 feet (24 inches) with an accuracy of ±0.1 inches. Note, Cell 1 (Sheet 10) will have the pressure transducer as part of its water quality probe while the other three cells will only have a depth transducer (Sheet 9). The wires from the stilling wells once outside of the pond should be buried at least 6 inches deep. Note, 18-inch extended mounting legs attached to the side of the stilling wells are to be used to properly anchor the wells in the media.

Pump Power Panel and Cellular Linked Programmable Logic Controller and Datalogger (PLC-D)

This section will present the minimum required specifications for the control system for the four pumps as well as how remote control of the pumps will be achieved. Sheet 12 shows an example of a control system that will meet the minimum requirements of this project, but alternative control systems are acceptable if they meet the following minimum requirements:

1. All electrical and control system components are to be located in a weather and vandal proof enclosure/panel that is mounted at eyelevel and can be securely locked. The panel should be located at NW end of the Cell # 4 infiltration pond (Sheets 2, 4b, and 9).
2. FPL will place a 240VAC single-phase transformer on their power pole as shown in Sheet 14, which will have a power drop to the project's temporary power pole with a meter box. This meter pole will need to be placed near their transformer pole, see Sheets 4b and 14.
3. A buried power line within a conduit from the meter pole to the pump control panel will be needed with a 100-amp rating and buried to a minimum depth of 24". The distance from the temp meter pole to the panel is approximately 30 feet, see Sheets 4b and 14. The power to the pump control panel will be single-phase 240VAC requiring a single-throw power disconnect.
4. Separate 20-amp breakers are to be provided for each of the four 240VAC pumps.
5. An 120VAC power outlet is to be provided at the Control Panel.
6. 120VAC power is to be provided to the Eureka Telemetry Panel from the pump control panel via a ~200-foot buried (minimum of 24") wire.
7. A 120 VAC to 12 VDC transformer is to be provided to lower voltage power for relays and float switches (Sheet 12).
8. 600 VAC 20-amp contact power relays are to be provided for each of the four pumps. A 12 VDC coil activation voltage is recommended, as shown in Sheet 12, but not required if an alternative relay activation voltage is shown to provide equivalent performance and safety.
9. Four manual pump control switches are required within the panel that will allow any pump to manually set to "Off", set to "On", or set to "Auto", which will allow remote control of the pumps via a cellular control module.
10. A cellular control module within the pump control panel is required to provide remote control by UCF staff of the four pumps (see Sheet 12). The contractor will be responsible for setting up and paying for the cellular service to the cellular control module.

Design and Specifications for the Components of the Infiltration Ponds and Drainage System

Ponds Construction

The ponds are to be constructed at shown Sheets 2 through 11. The top of berm elevation of 33.0' (NGVD29) will be the same for all ponds, which is set to provide as close as possible an even cut and fill ratio. The above ground berms are to be compacted to standard STMP specifications.

Ponds Liners

Each pond will be lined with a minimum of a 40mil HDPE plastic liner which is to be anchored at the top using an anchor trench (Sheets 4a, 4b, 5, and 7). Each cell will require approximately 1,704 ft² of liner material or about 6,814 ft² for all the ponds. A liner boot will be required in the bottom NE corner of each cell to allow the 4” diameter manifold pipe in the ponds to be connected watertight to the 4” solid drainpipes that will deliver the water to the drainage control boxes, see Sheets 2, 4a, 4b, and 5.

Ponds Drainage System and Outflow Control Boxes

Each of the ponds will have 4-inch diameter perforated plastic drainpipes embedded in 6 inches of gravel (~10 yd³ per pond or ~40 yd³ for all four ponds) at the bottom of the ponds (Sheets 4a, 4b, and 5). Note a geotextile porous fabric material must be placed on top of the gravel to prevent media intrusion. A 4-inch diameter perforated plastic drainpipe will serve as the collector manifold for the three 4-inch drainpipes (Sheets 4a, 4b, and 5). A 4-inch liner boot in the bottom NE corner of each cell will be used to make a water tight connection between the internal 4-inch manifold and the 4-inch diameter solid drainpipe (sewer grade acceptable) that will deliver the drainage water to four drainage control boxes located at the NE corner of Cell # 1 (Sheets 4a, 4b, 5, and 6). These control boxes will allow the discharge head for each of the cells to be set independently and allow the flowrates to be controlled and measured via a water depth probe / pressure transducer providing the head over a V-notch weir within the control box. The 4-inch discharge drainpipes from these control boxes will be connected into an 8-inch solid drainpipe that will deliver all of the cells’ drainage water back to the C-23 canal (Sheets 2, 4a, and 10).

Bio-Sorption Activated Media (BAM)

Two different types of sorption media are to be placed in the four cells on top of the gravel level at a depth of 2 feet. Cells 1 and 2 will have the ZIPGEM media and Cells 3 and 4 the CPS media. Each cell will require ~50 yd³ of these sorption materials, therefore ~100 yd³ of ZIPGEM and ~100 yd³ of CPS will be required. The mixing recipes for the two media types are provided in the following table:

Name	Sand (%)	Clay (%)	Tire Crumb (%)	Iron Filings (%)	Perlite (%)	Biochar (%)	Natural Soil (%)
CPS	92	5	--	--	3	--	--
ZIPGEM	85	5	--	5	5	--	--

Data Acquisition (Remote and In-situ)

Weather Station (to be provided by others)

A weather station will be installed and connected to the Eureka Telemetry Panel by Eureka so that local rainfall, temperature, wind, and solar radiation can be continuously measured and recorded, see location in Sheets 2 and 4a. Therefore, the contractor should not bid on this item.

Measuring Inflow and Outflow Rates

As indicated above, the canal inflow to each cell will be measured using flowmeters installed on the inflow lines to each cell. These flowmeters will be read and recorded manually by UCF staff during each site visit.

The outflow from each cell will be measured using the pressure transducers on the Eureka water quality probes located in the drainage control boxes. The probes will provide the water depth/head over the weir plate in the control box, which can be used to calculate the flowrate. These data will be able to be remotely downloaded via the Eureka Telemetry Control Panel.

Water Quality

The control boxes will have Eureka water quality probes placed within them in order to remotely obtain continuous water quality data. Note, one additional water quality probe will be placed in the stilling well in Cell #1 in order to obtain the same water quality data for the canal inflow water. These data will be able to be remotely downloaded via the Eureka Telemetry Control Panel. In addition, it is recommended that during each UCF site visit, manual water samples be collected for the canal water in the one of the ponds and from the outflow boxes and to verify the remotely obtained data.

Site Video Feed

A camera is to be placed at the Pump Control Panel and connected to a cellular system (see Sheet 12) so that visual site surveillance is available remotely during the duration of the project.

Site Access and Construction Permit Requirements

Site Access Through the Cobblestone Homeowners Association (HOA)

Access to the site will be via a private road (Stuart West Blvd.). The HOA has granted project personnel access but will require personnel to contact the security staff via text or phone that they are with the project and when they need access. Contact information for the HOA security will be provided by UCF.

Site Access Requirements for District Property

The awarded contractor will be required to apply for and receive a permit for temporary access and/or staging necessary to perform the authorized work from the South Florida Water Management District. UCF and SWET will help the vendor obtain this permit. This application shall include all details regarding the means, methods, needs, scheduling, or other activities related to actual construction of the proposed improvements (i.e., staging of materials, access,

vehicle types, duration of construction, etc.) This Temporary Access Permit may be subject to additional criteria including, but not limited to, providing proof of insurance as well as financial assurance to cover costs necessary to repair any damage to the District's right of way that may result from the construction and/or installation of the proposed work. Temporary access and storage criteria is described in further detail on the Right of Way Section's webpage on the District's website www.sfwmd.gov.

Sediment and Debris Control

A silt fence will not be required to prevent debris from entering the cells because of the low berm being constructed around them. Also, offsite debris losses will also not be an issue because of the flat sandy soils at the project site and the fact that the land to the south of the SRWMD ROW is upgradient.

Routine Site Maintenance

Routine site trimming and mowing maintenance services are requested by the contractor for the duration of the project, which will be 1 year. Mowing and weed whacking around site equipment are to be done a minimum of five times per year. The contractor will also be responsible for setting up and paying for the electrical and cellular services to the project. The anticipated period would be 8/22 to 5/23.

Project Decommission

After the completion of the project in 1 to 2 years, the site is to be decommissioned according to the following specifications: The Eurika telemetry system and all sensors connected to it and the weather station, which are being provided by UCF, will be removed by UCF staff at the end of the project. All other equipment and materials will become the possession of the decommissioning contractor and must be removed or buried onsite as follows. The equipment and materials to be removed offsite include all pumps, the pump control panel, the temporary power pole, drainage control boxes, outlet rip rap, flowmeters, bubbler rip rap pads, stilling wells, and electrical wires. Prior to the covering of the media within the ponds using the soil within the pond berms, all liner material within 1 foot of natural ground grade is to be removed and disposed of and at least four >10 ft² drainage breaches must be created in the remaining liner at the bottom of the ponds to allow for natural drainage through the soil and media. The berms will provide enough soil to cover the ponds with approximately 18" of soil, which will result in the top of the recovered area being about 12" above natural grade. The replaced soil must be evenly graded with the side slopes to the natural grade of at least 6:1. Once final grading is complete, all disturbed soil surfaces are to be mulched and seeded. Decommissioning shall be completed within 2 months of project completion. UCF will provide the contractor with a minimum of a 3-month notification of the project termination date.

Construction Oversight

The selected contractor for the project shall provide continual professional oversight during construction to ensure it is constructed to project design and SFWMD construction specifications. Soil and Water Engineering Technology, Inc. (SWET) will work with the contractor during construction to provide technical support and quality control oversight. The

contractor is to provide a video recording of construction and decommissioning activities. SWET will also coordinate with the contractor during the startup, testing, and verification of proper functionality, and will certify successful construction completion. The contractor shall remain available to provide repair/maintenance and warranty services for installed equipment at a separate fee.

Figure 1. Stage in the C-23 Canal upstream of Structure S97.

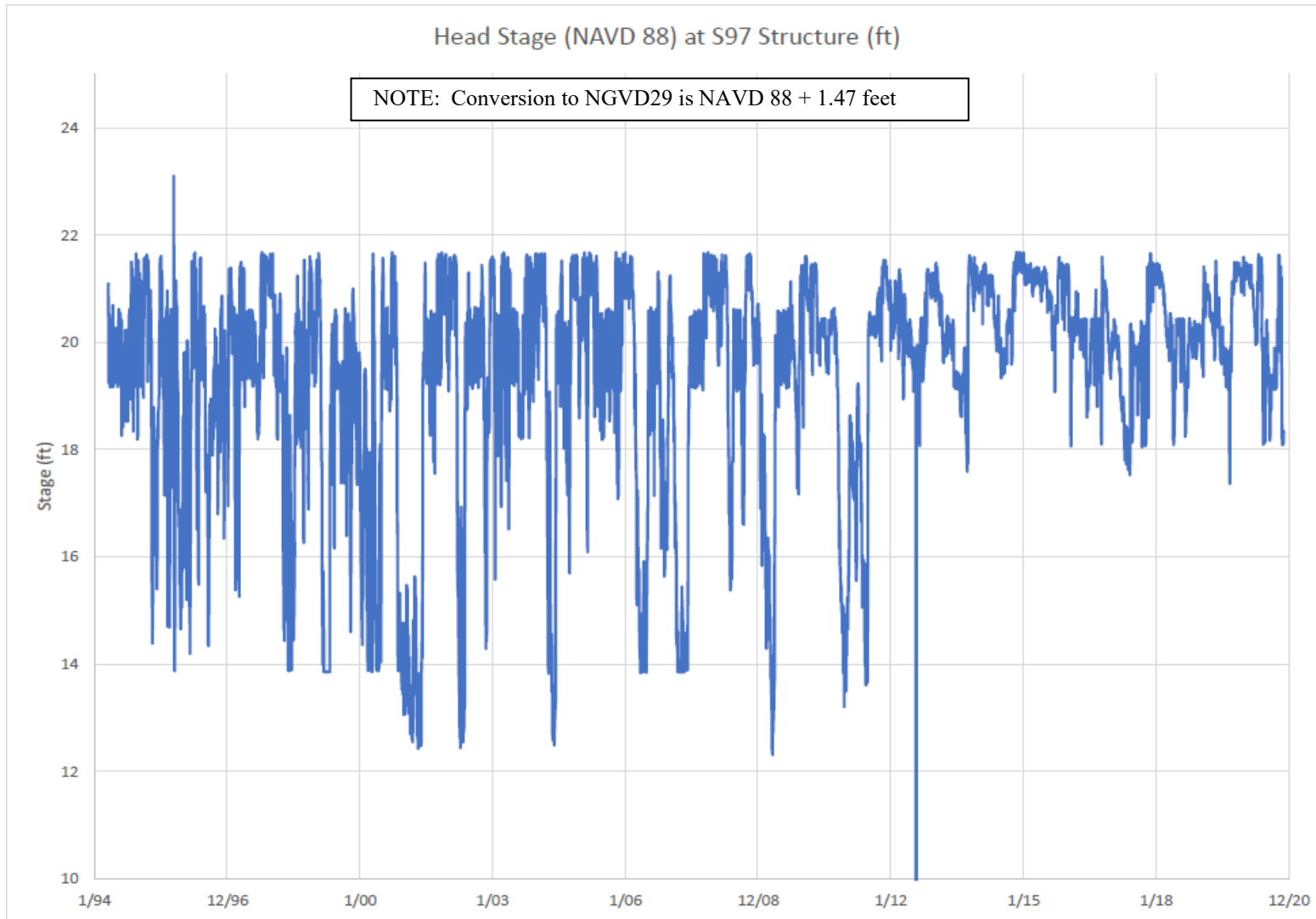

Attachment 6 – Design Drawings

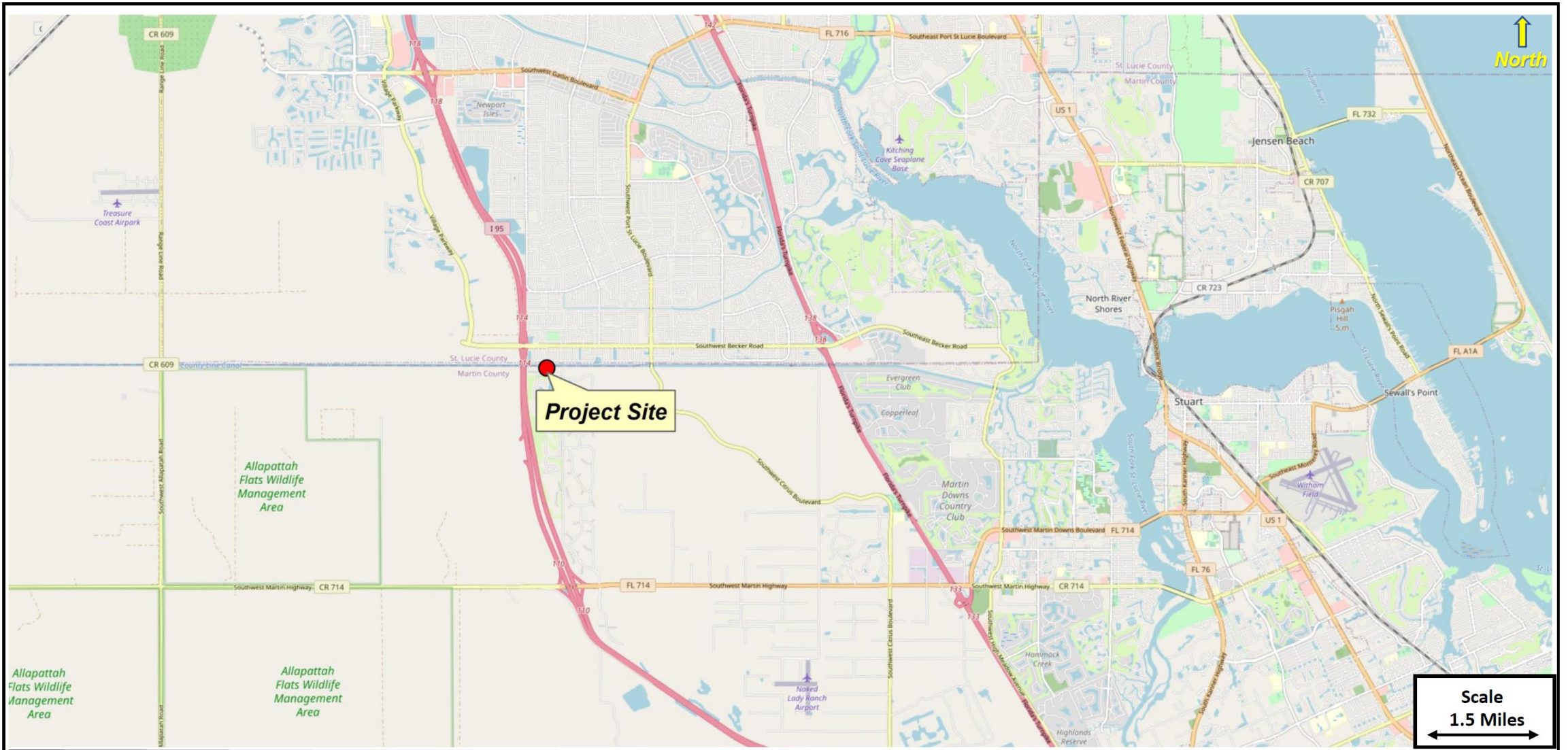

Sheet 1. Locator Map

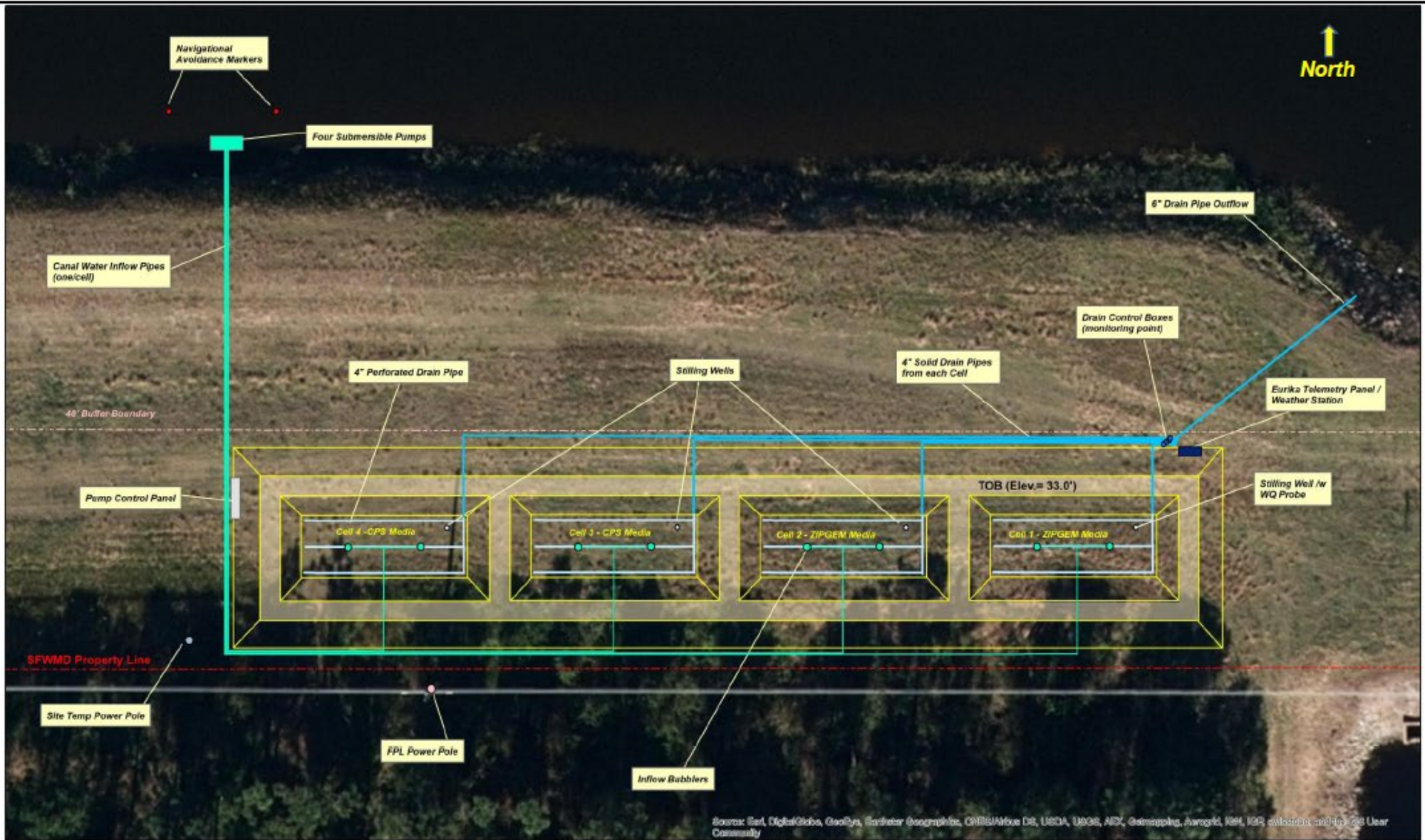

Sheet 2. General Layout of the C-23 Canal Bio-Sorption Activated Media Filtration to Reduce Nutrients and Algal Mass Project

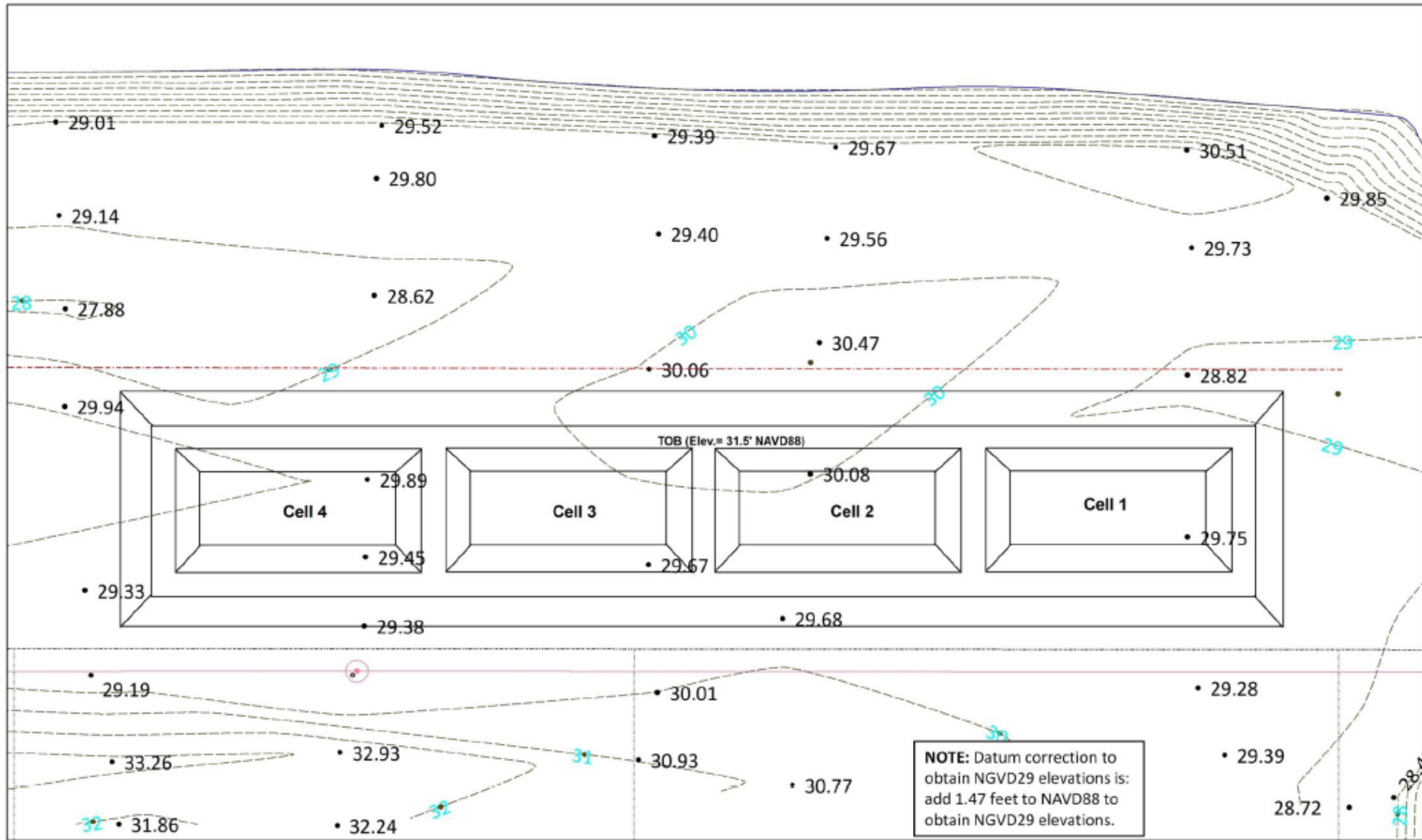

Sheet 3. Site Layout with Recent Topographical Survey (NAVD88)
(Survey Completed by Altamax Surveying, Casselberry, FL)
(See Datum correction note for NGVD29)

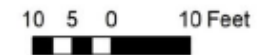

Plan View of Cells 1, 2, and 3

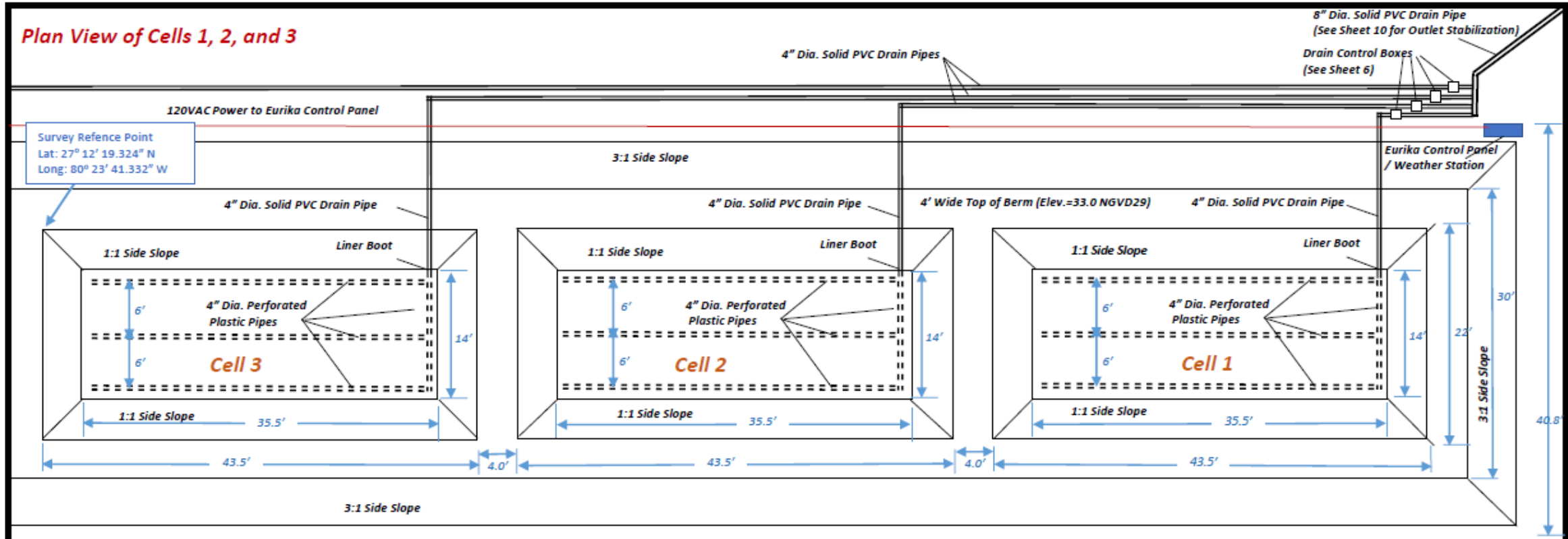

North Profile View of Cells 1, 2, and 3

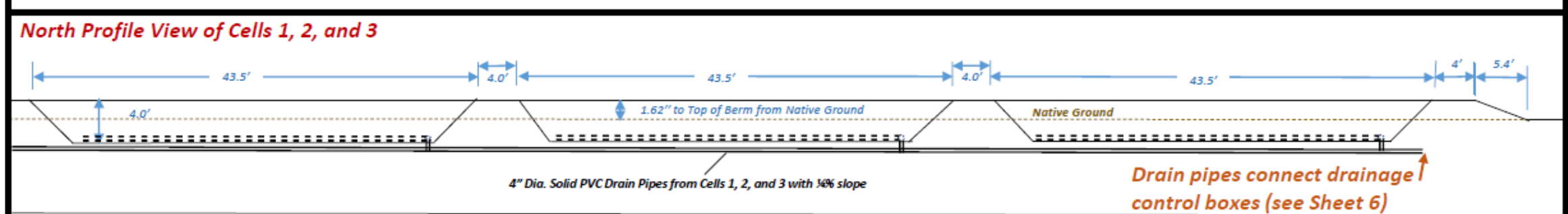

Sheet 4a. Infiltration Pond Layout (Plan and North Profile View of Cells 1, 2, and 3)

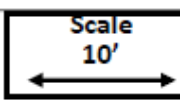

Plan View of Cells 4, 3, and 2

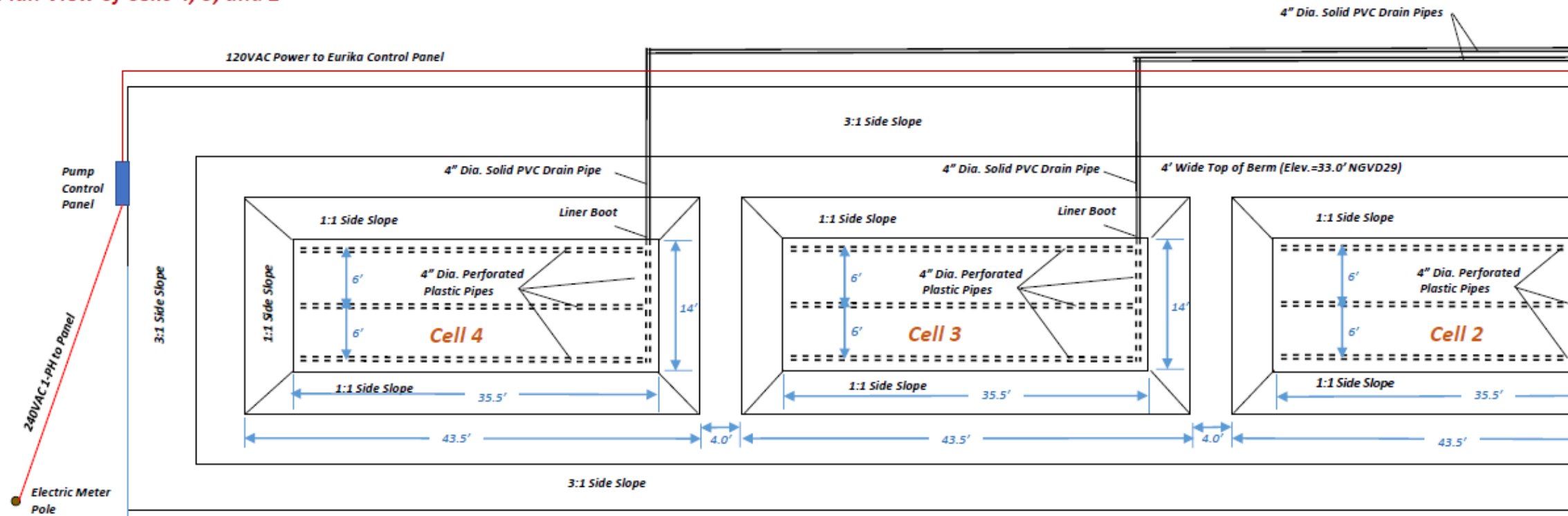

North Profile View of Cells 4, 3, and 2

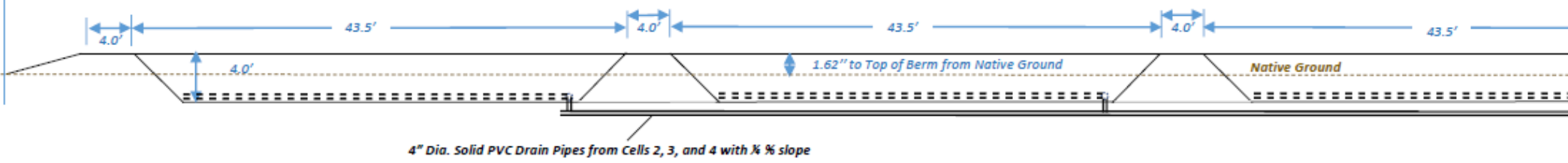

Sheet 4b. Infiltration Ponds Drainage Layout (Plan and North Profile View of Cells 2,

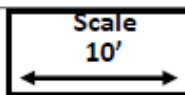

West Profile View of Drain Pipe Layout for Cell 1

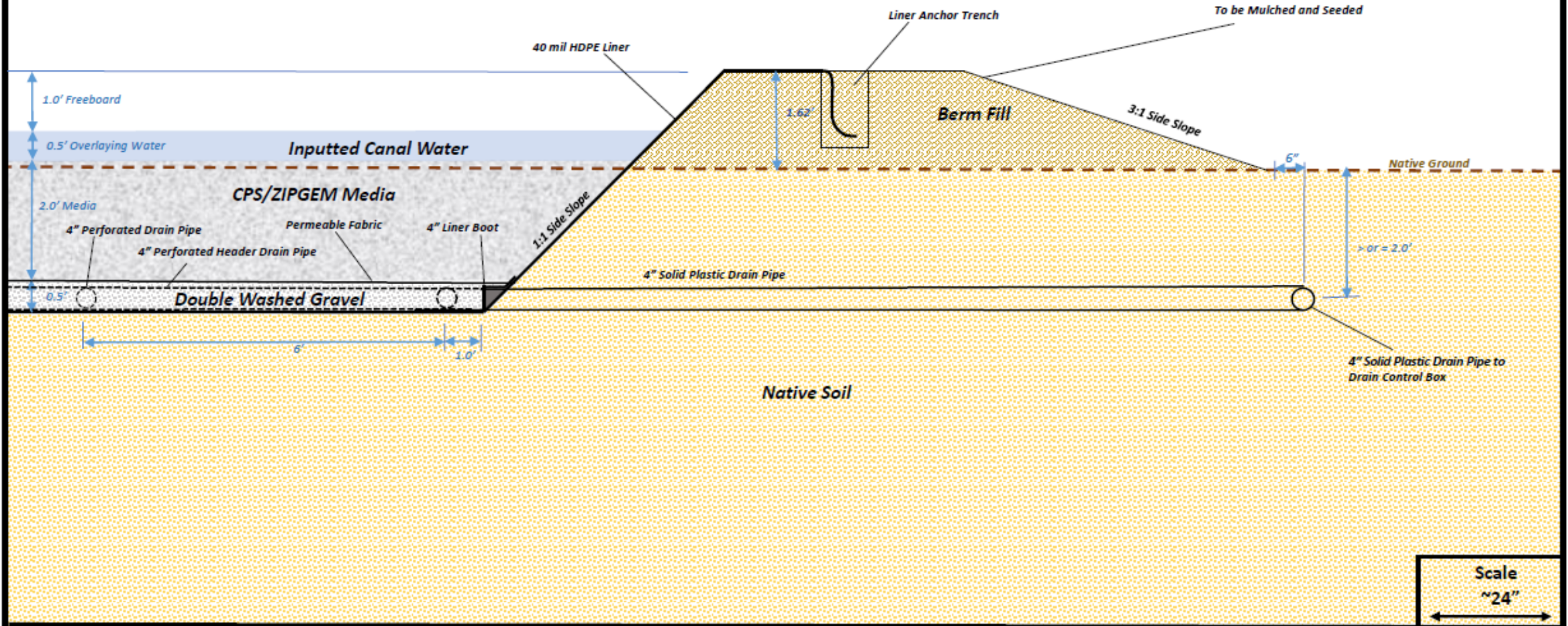

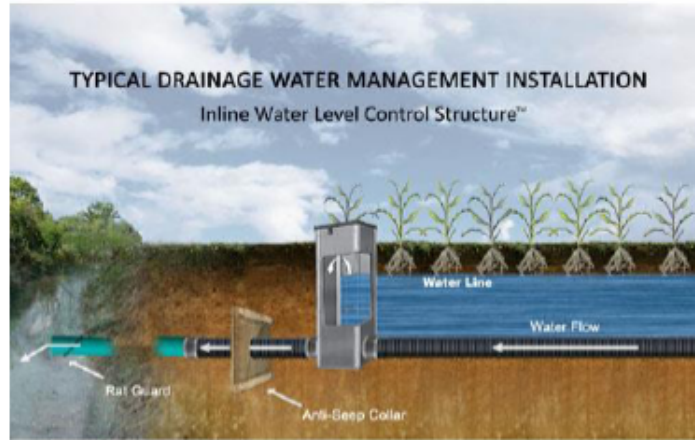

[Inline Water Level Control Structures™ \(agridrain.com\)](http://agridrain.com)

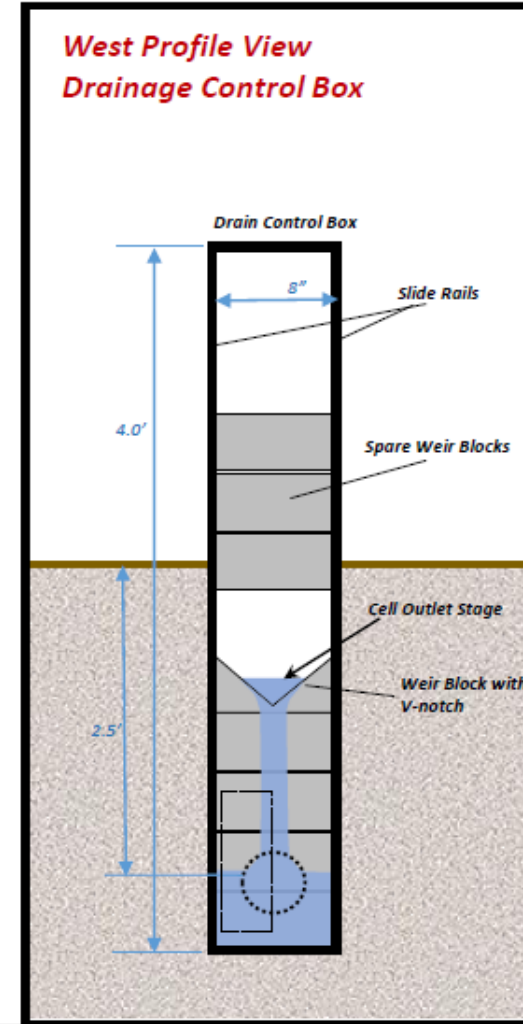
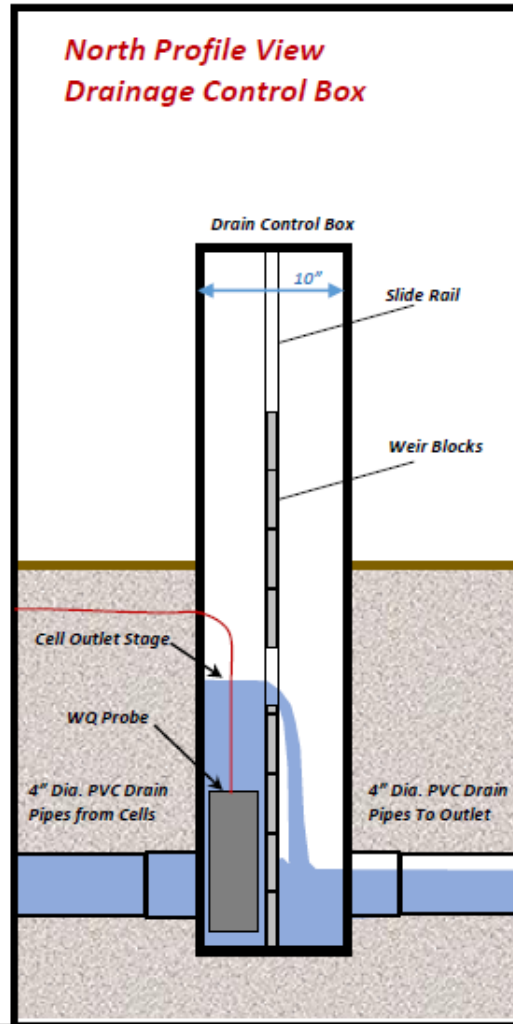

West Profile View of Drain Pipe Layout for Cell 4

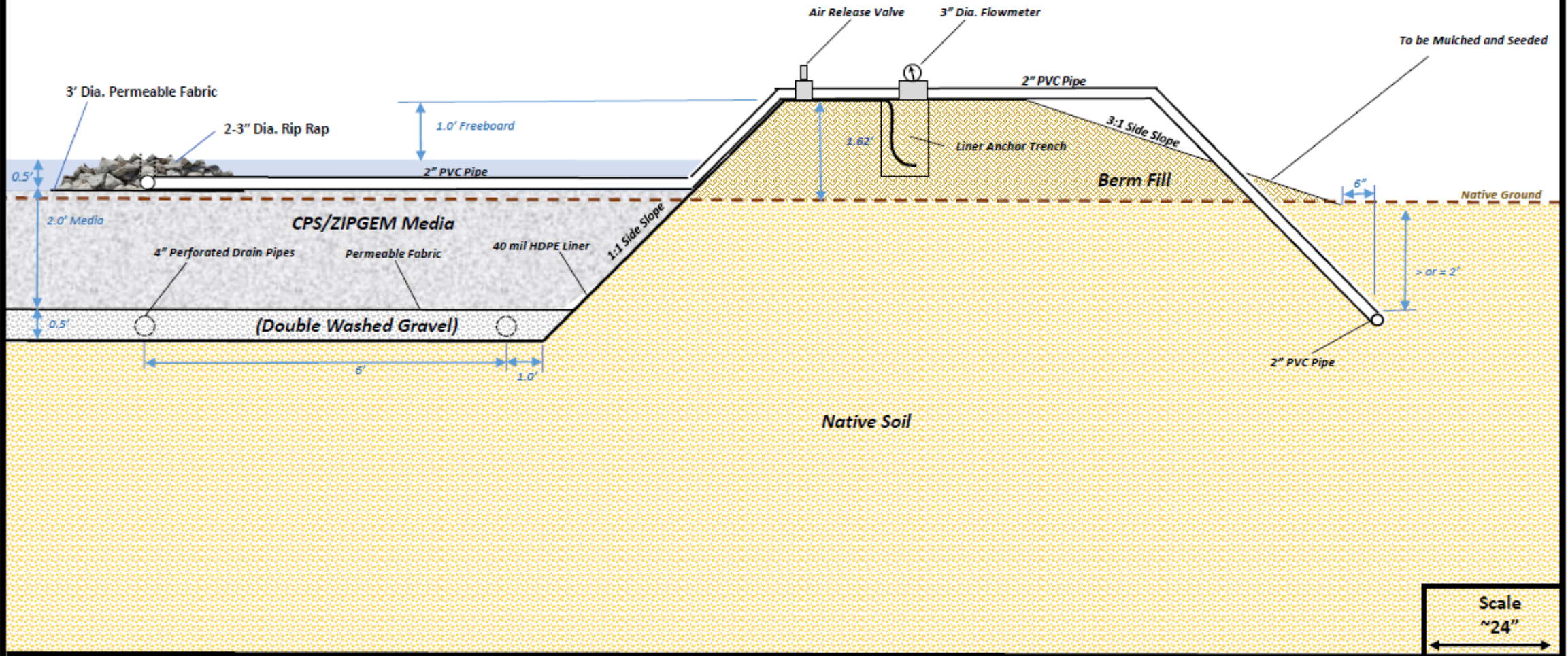

Sheet 7. East Profile View of Cell 1 Inlet Pipe from Pump

Plan View of Cells 1, 2, and 3

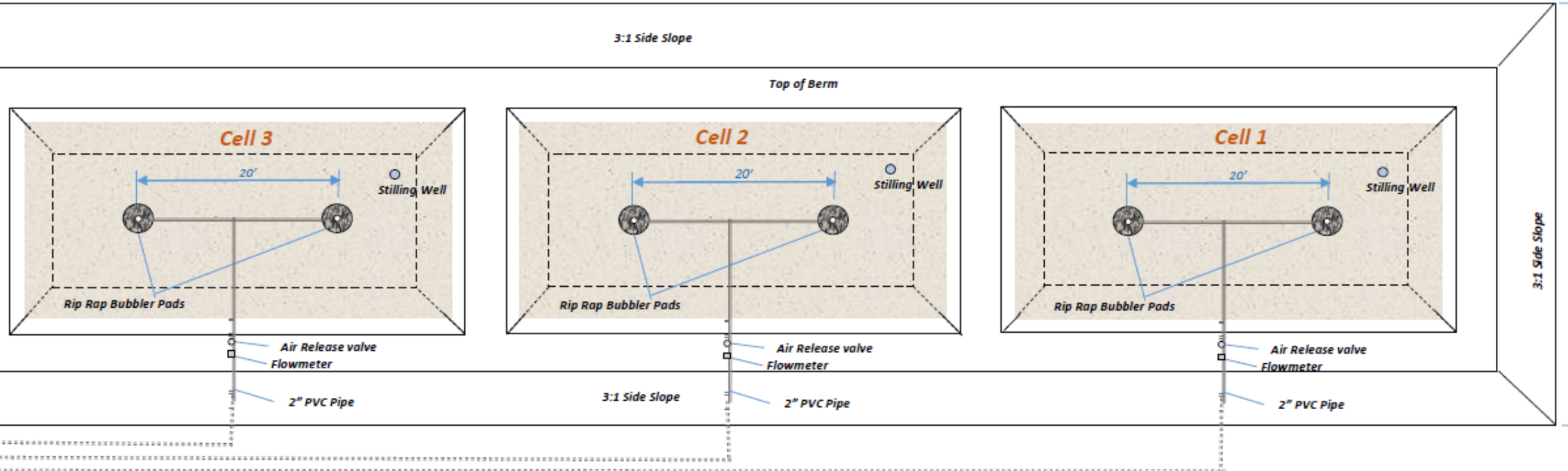

North Profile View of Cells 1, 2, and 3

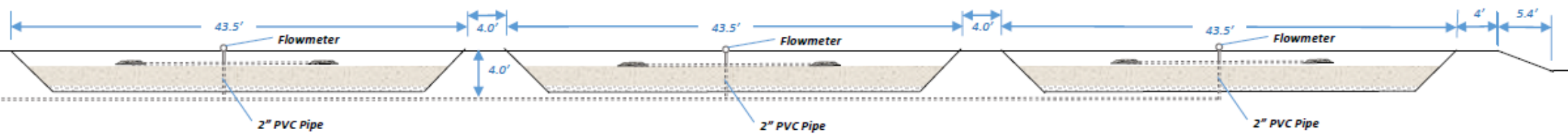

Plan View of Cells 2, 3, and 4

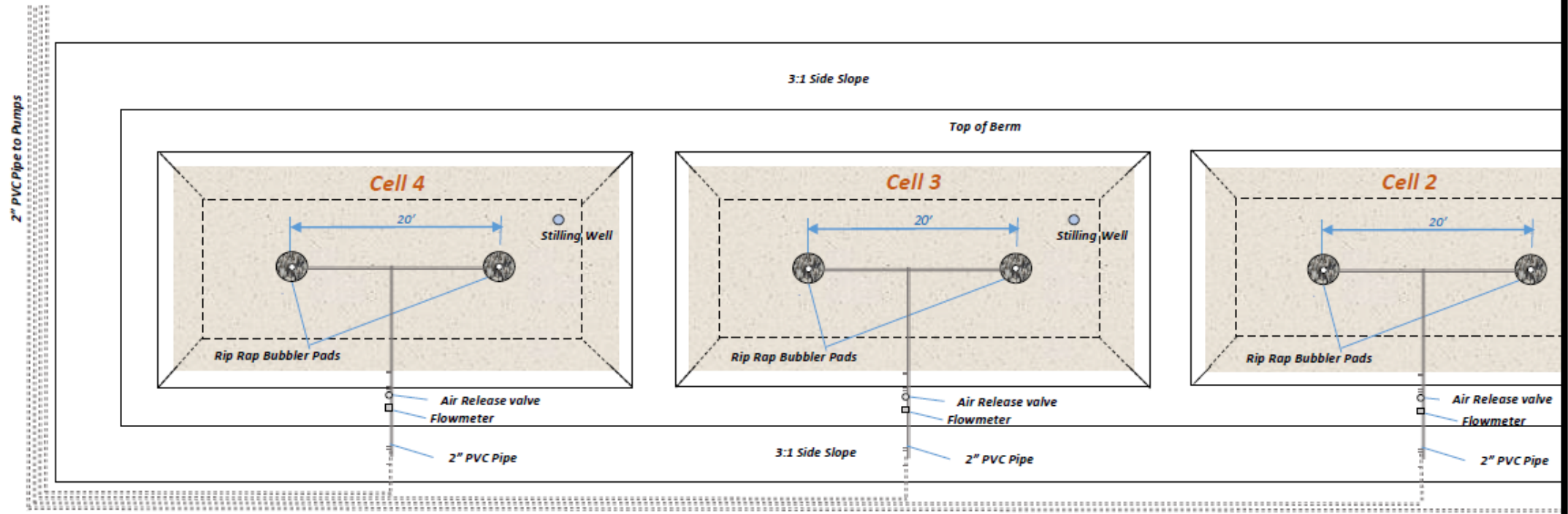

North Profile View of Cells 2, 3, and 4

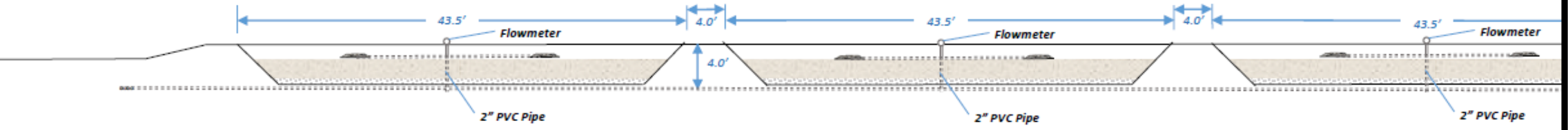

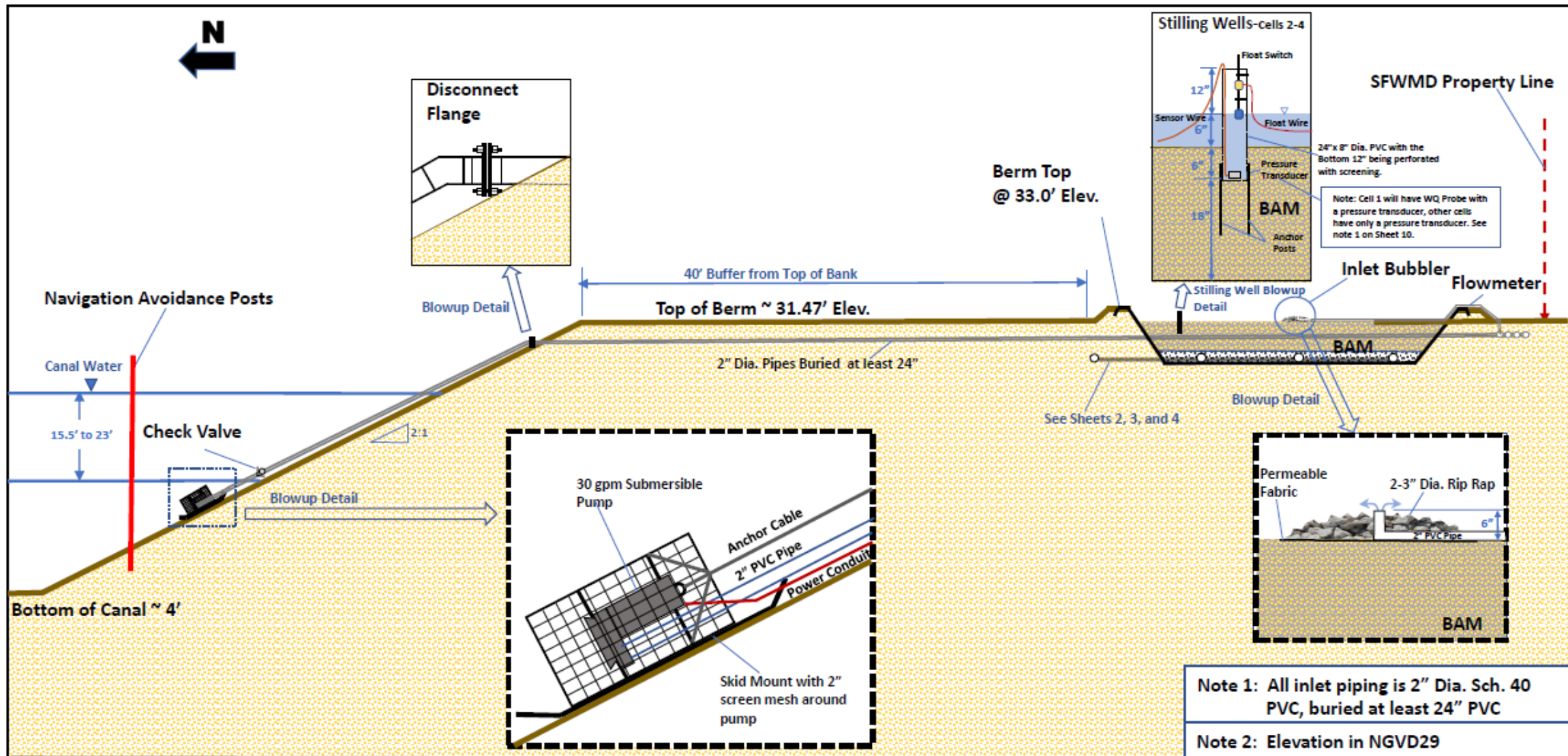

Sheet 9. General Layout of Pump and Drainage Systems

Note 1
WQ Probe Installation

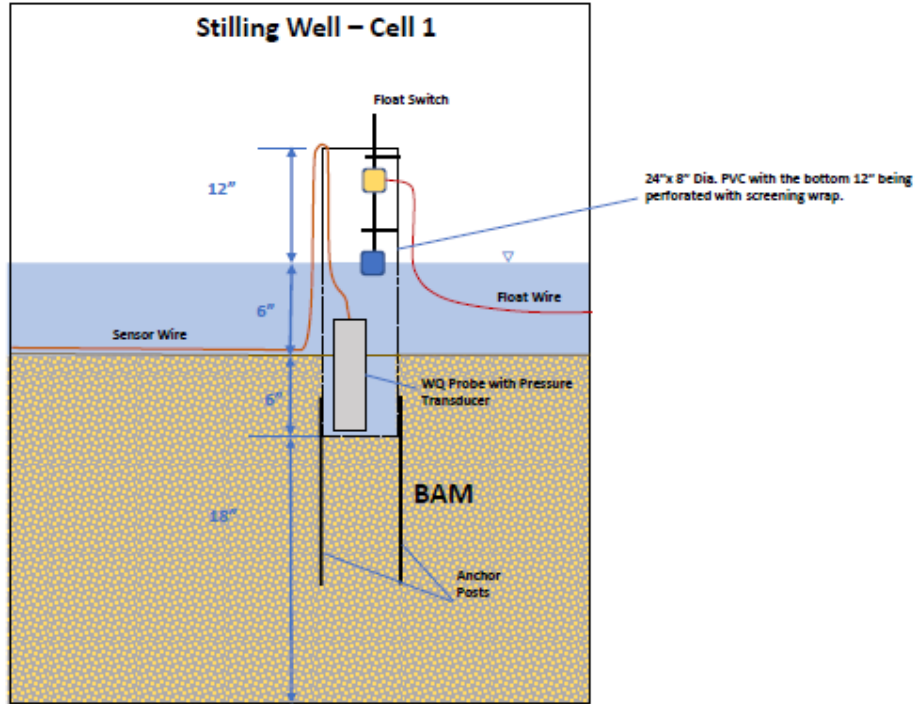

Note 2
Riprapping of Outlet Pipe

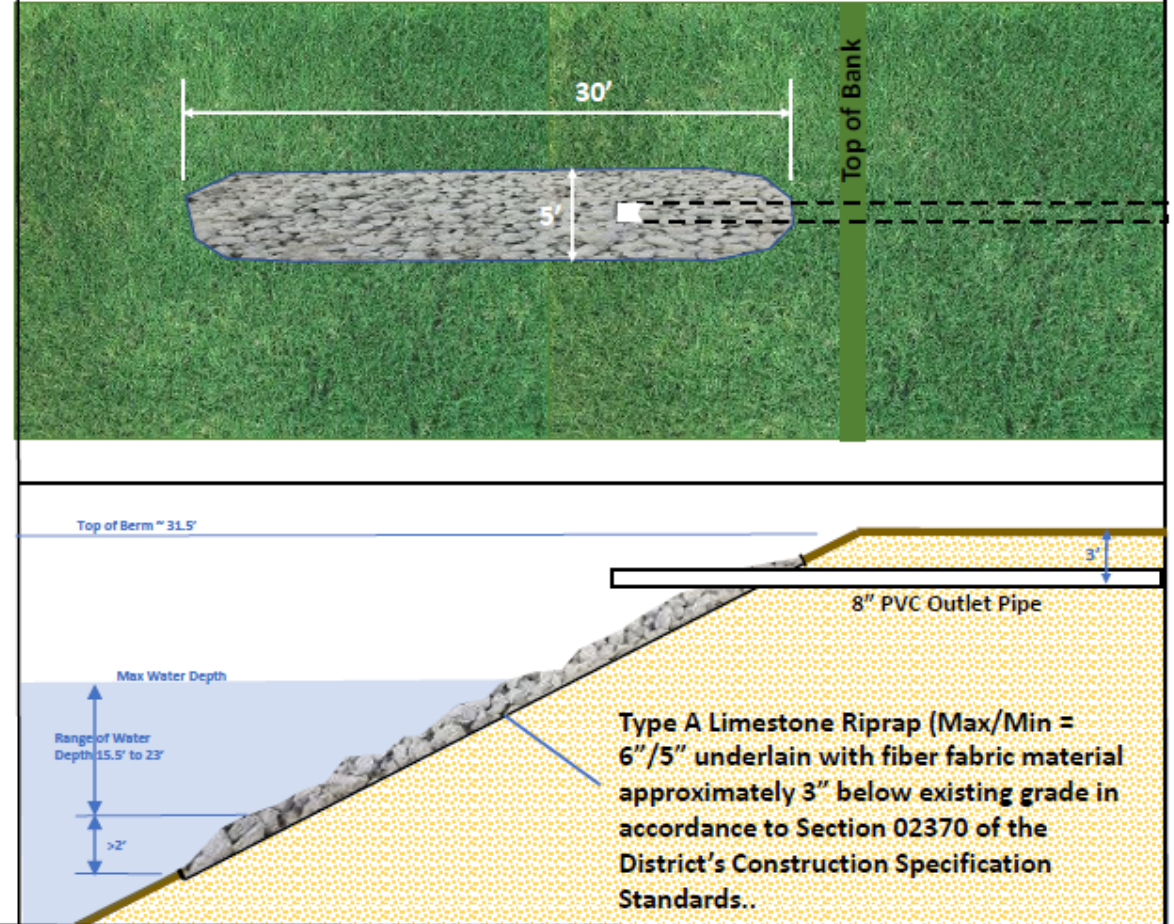

Sheet 10.

Note 1: Cell 1 have a WQ Probe with pressure transducer, where all other cells has only a pressure transducer as shown in Sheet 9.

Note 2: Outlet Pipe Details.

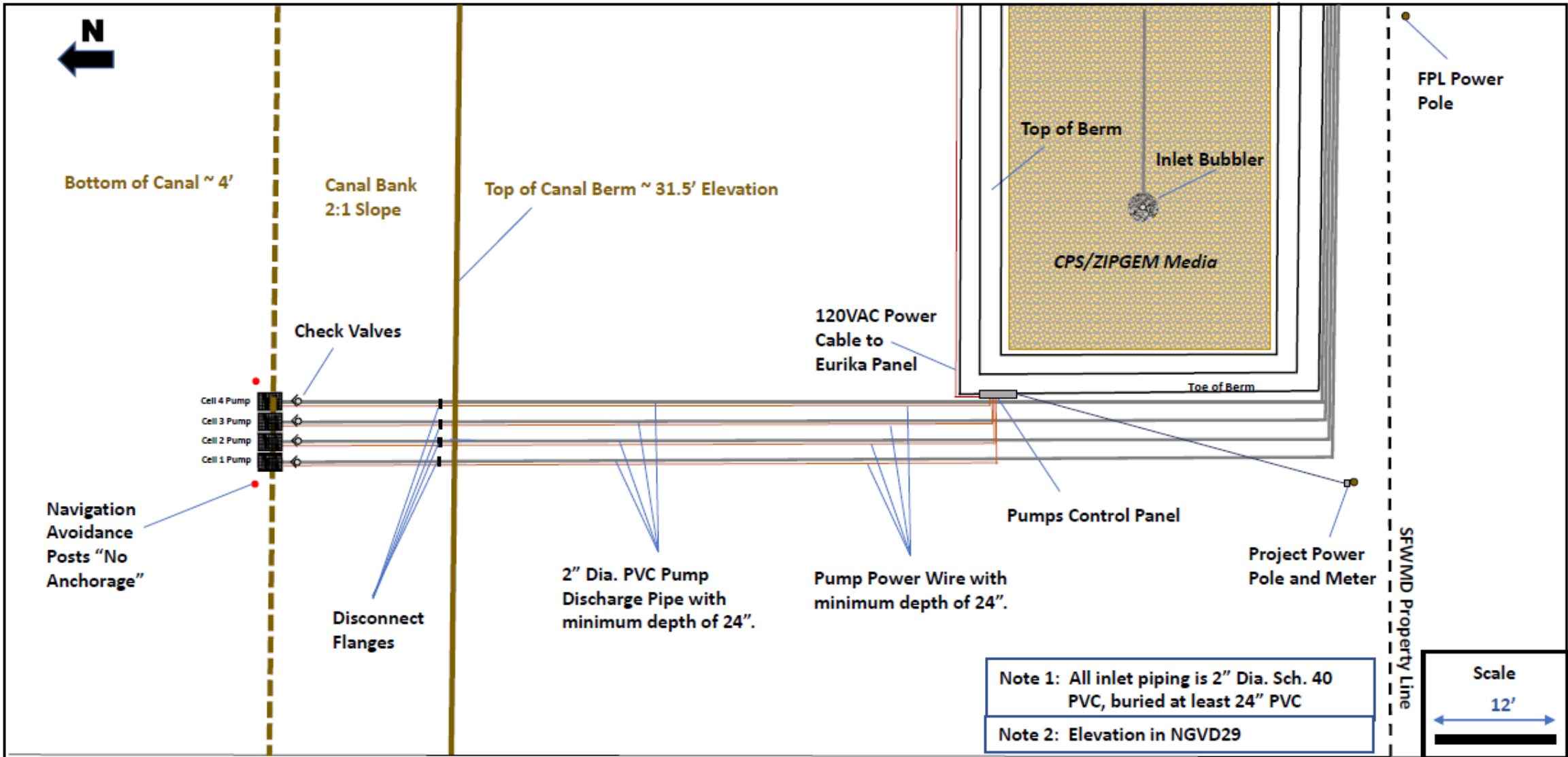

Sheet 11. Pump and Pipeline Layout

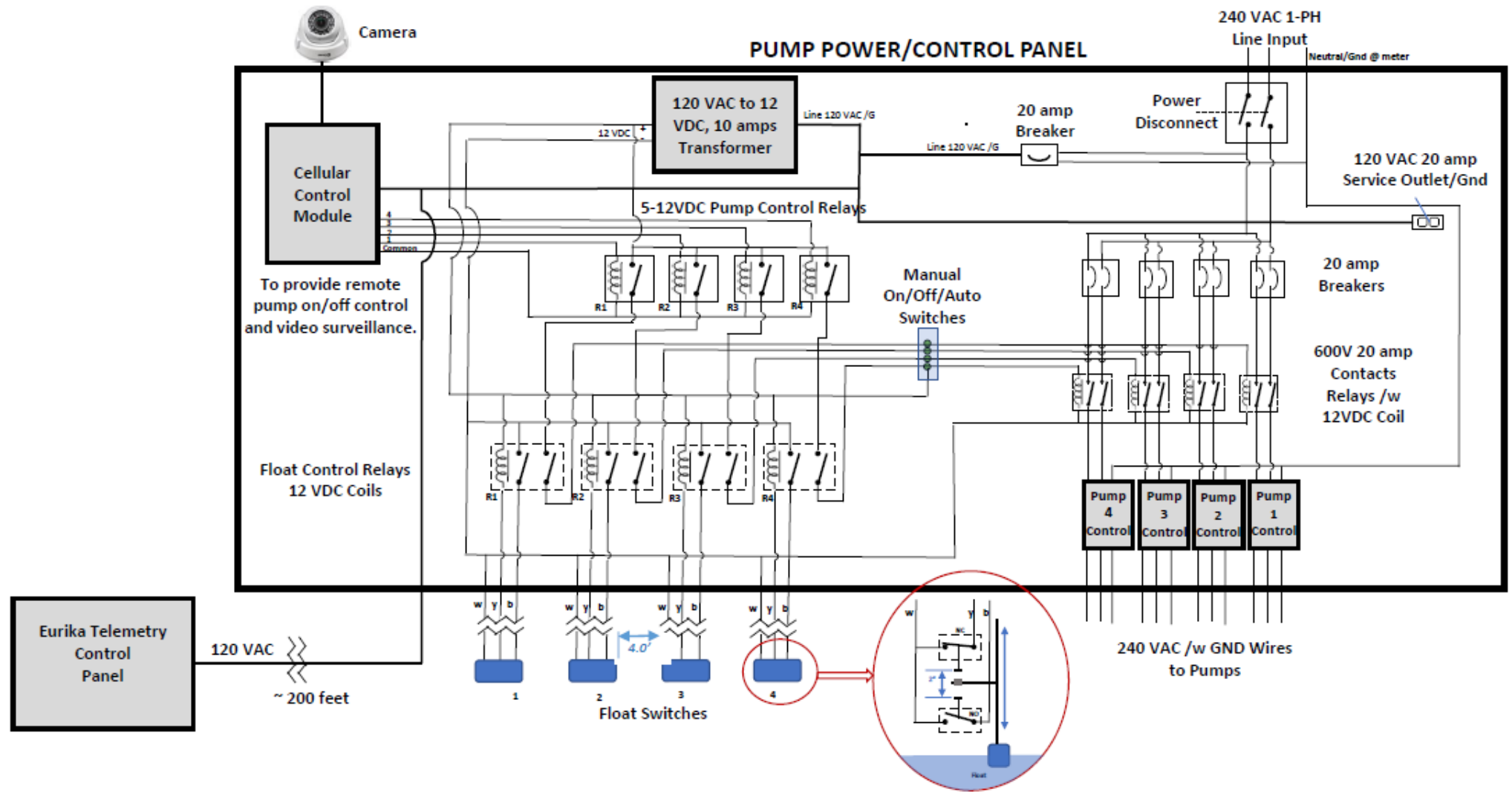

Sheet 12. Pump Power Control Panel with Pump Control Signals from Eureka Telemetry Panel



Source: Esri, DigitalGlobe, GeoEye, Earthstar Geographics, CNES/Airbus DS, USDA, USGS, Aero, Qamappa, AeroGRID, IGN, IGP, swisstopo, and the GIS User Community

Sheet 13. Ingress and Egress for Project Site.

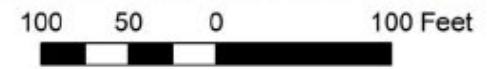

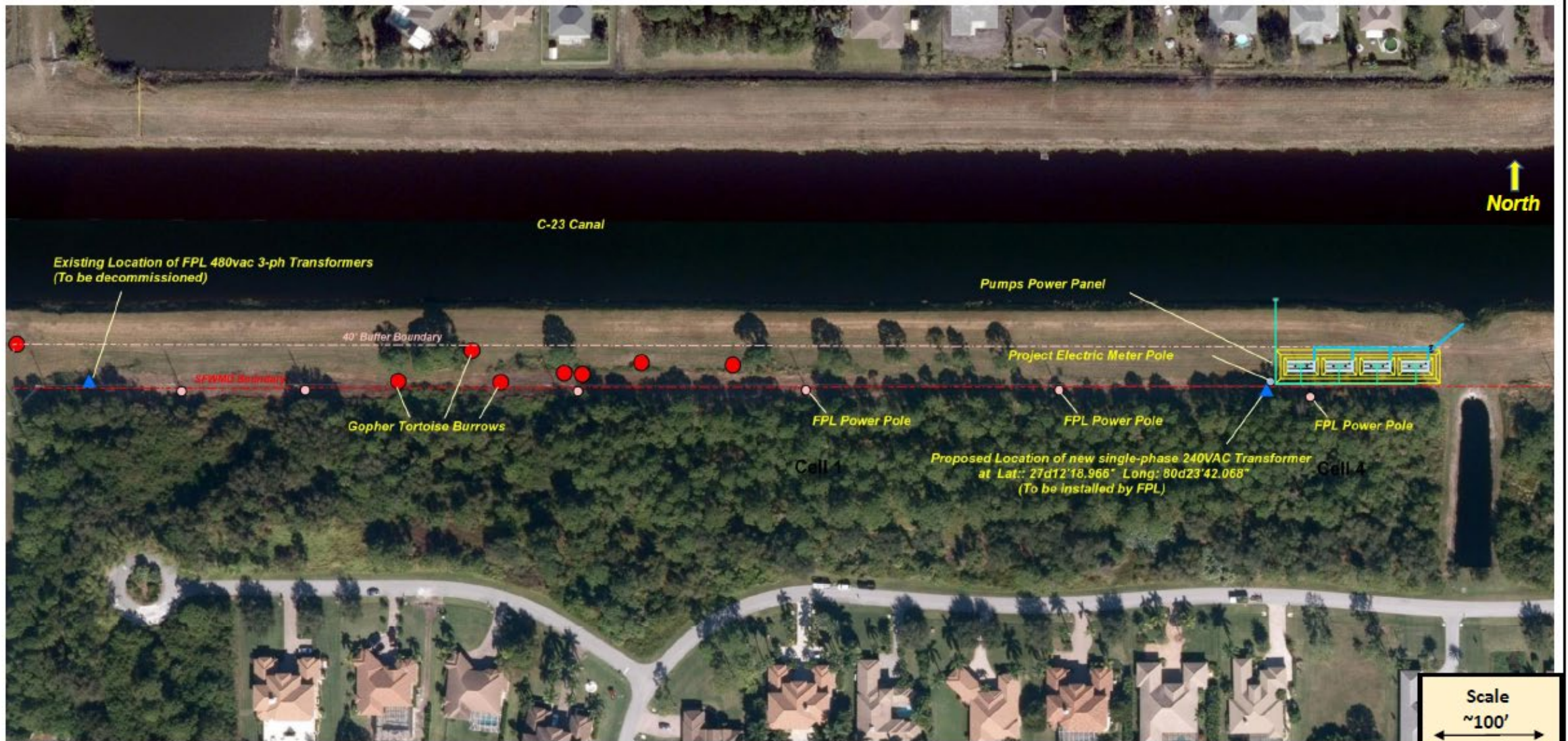

Sheet 14. FPL Power Supply. Locations of existing 480vac 3-ph transformers to be decommissioned and a new 240VAC transformer. Gopher Tortoise Burrows locations shown as red dots.